

Cod. 570074

1075 x 375 x h 420 mm



ASSEMBLY
TUTORIAL



MAINTENANCE
TUTORIAL

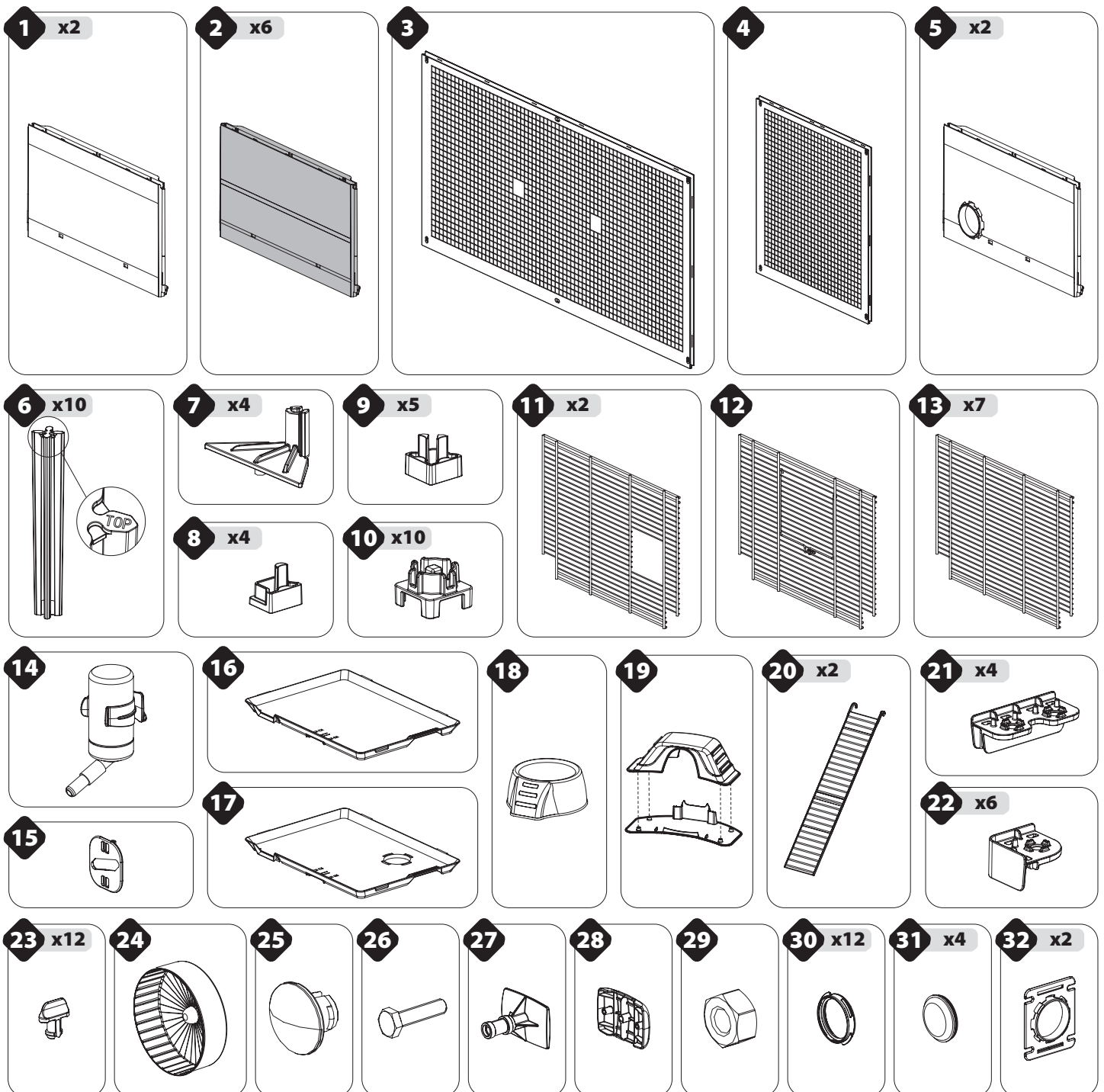

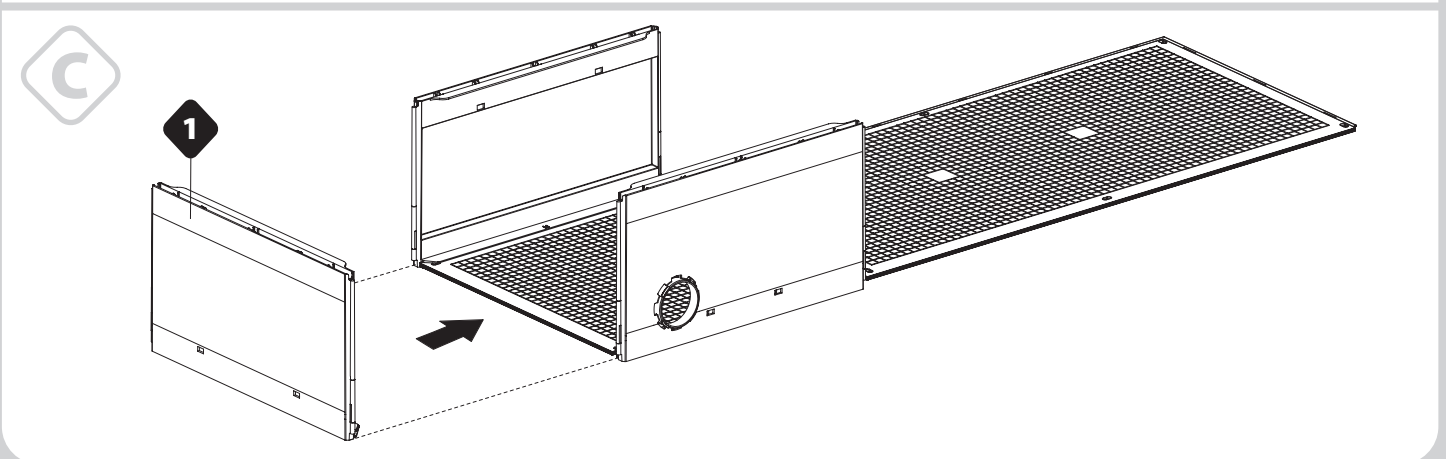
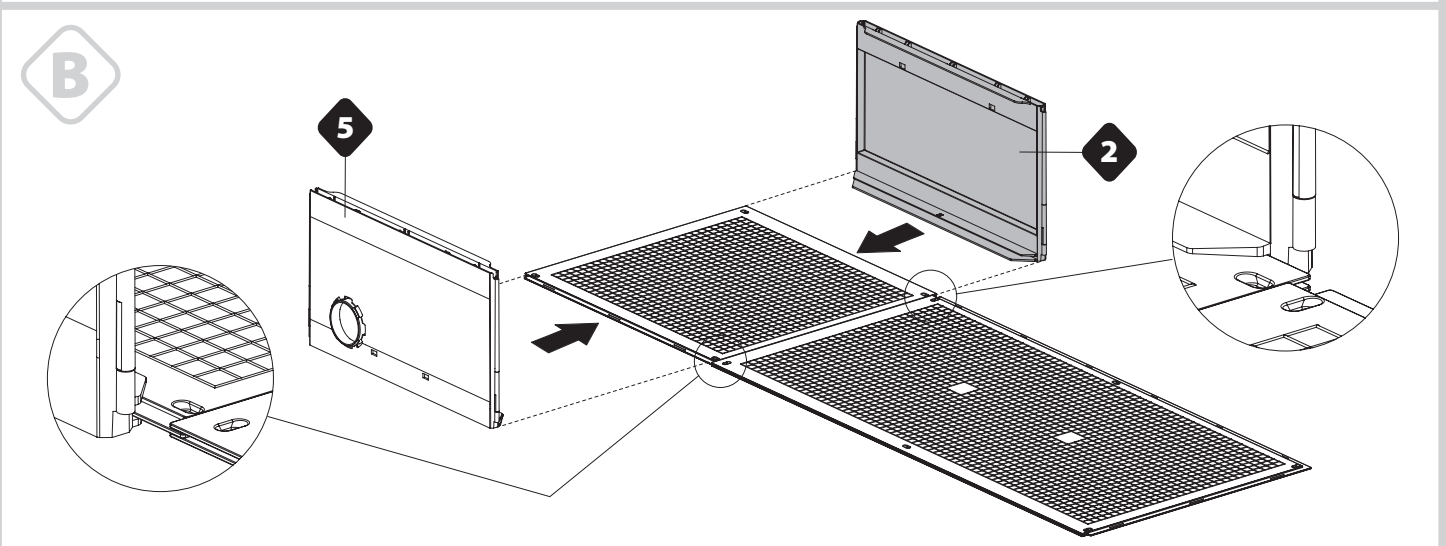
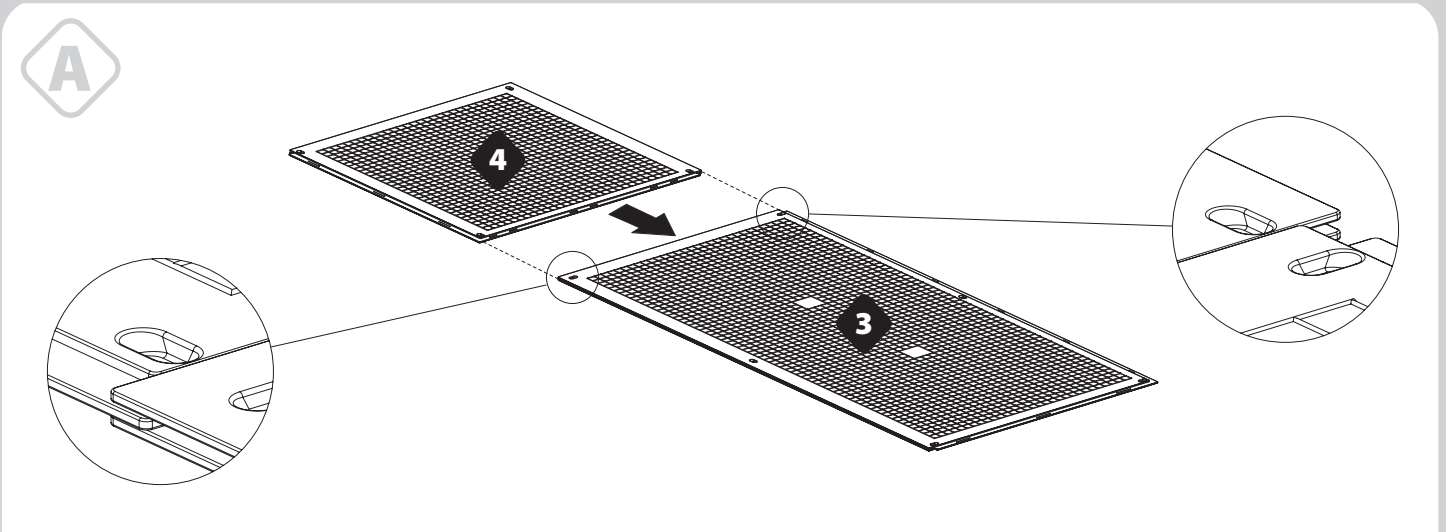
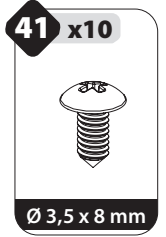
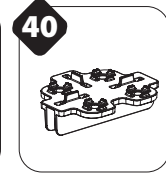
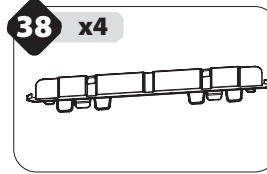
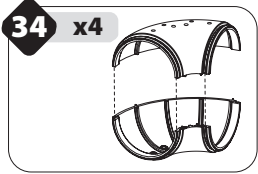
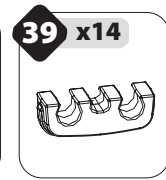
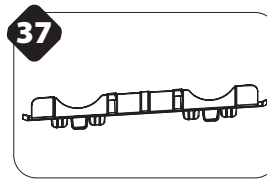
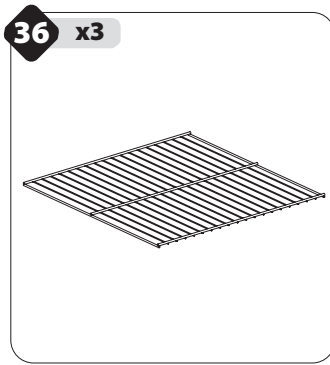
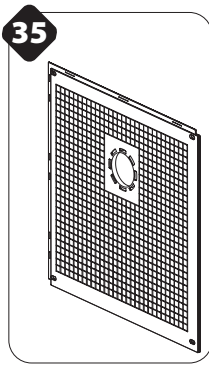
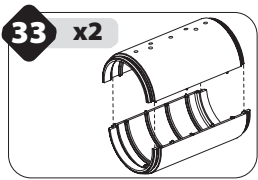

D

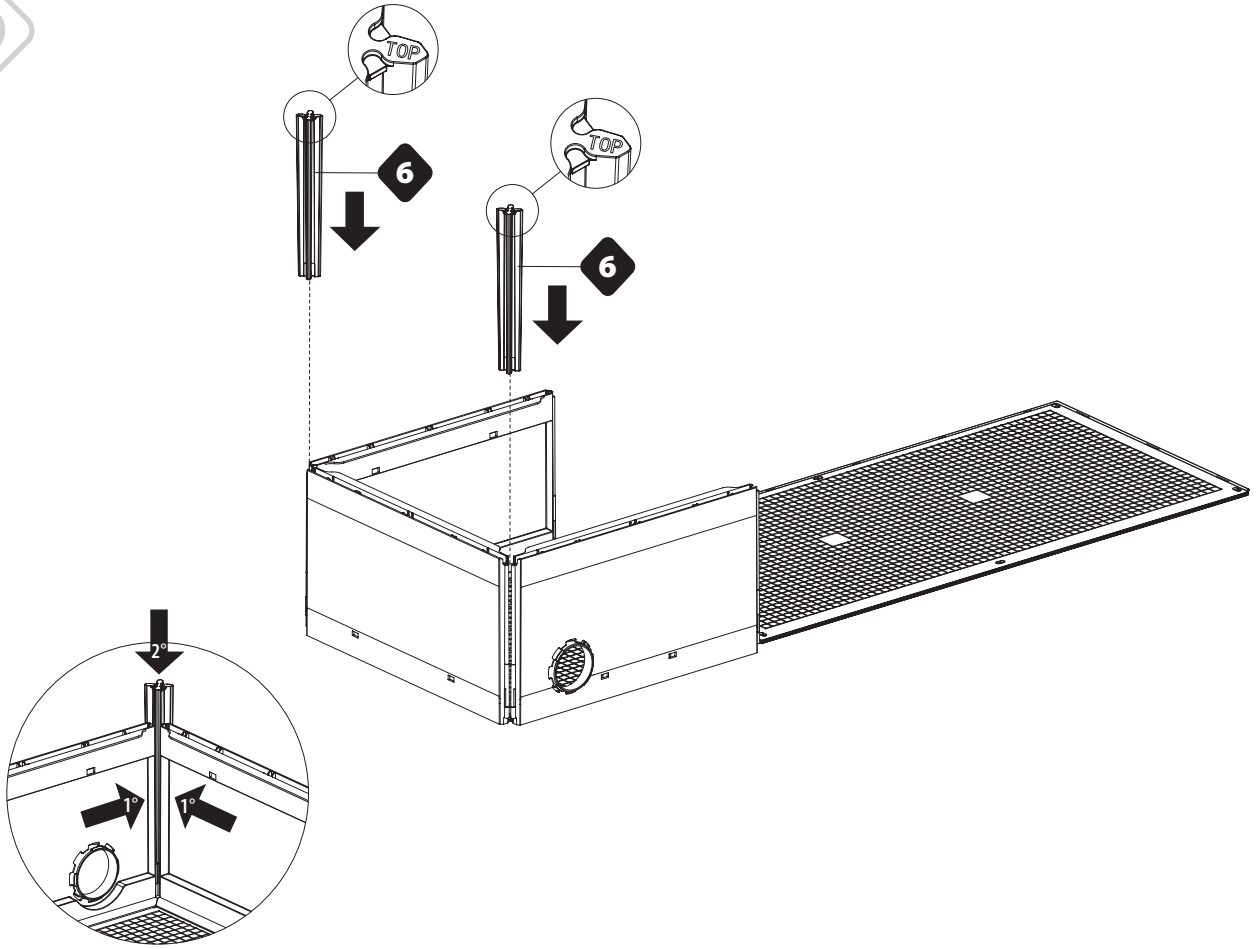

E

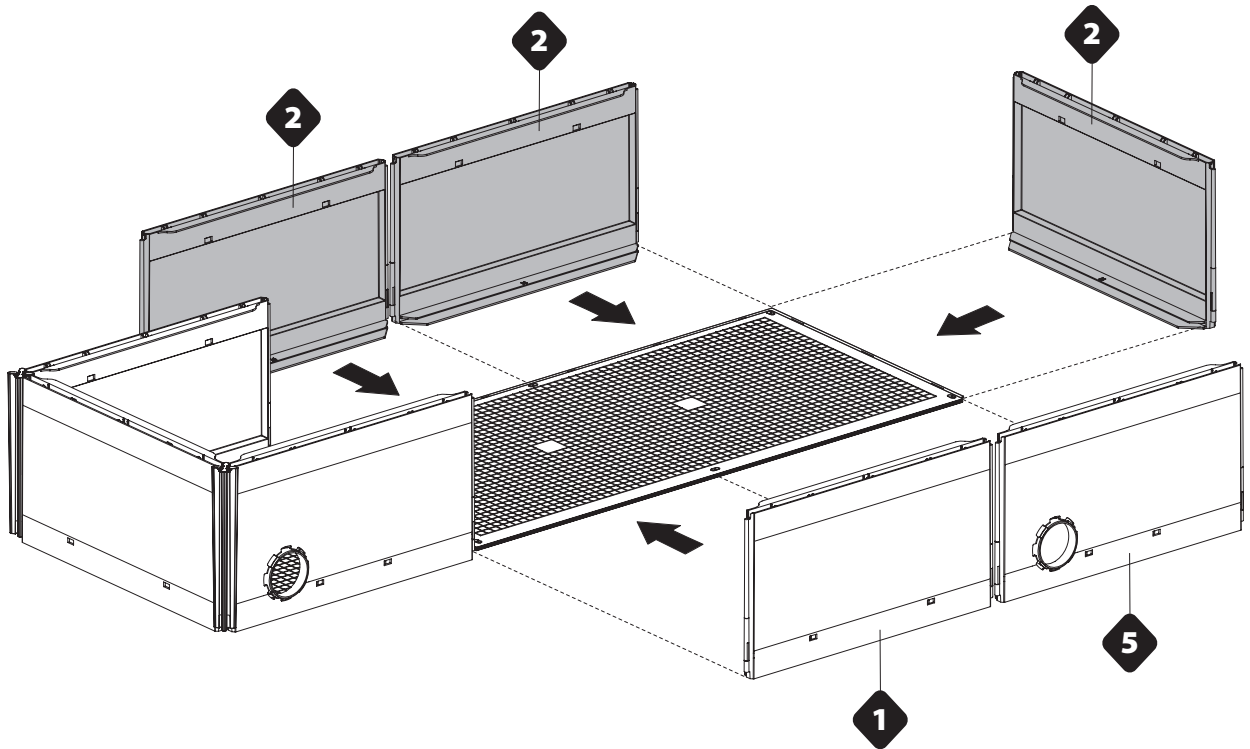

F

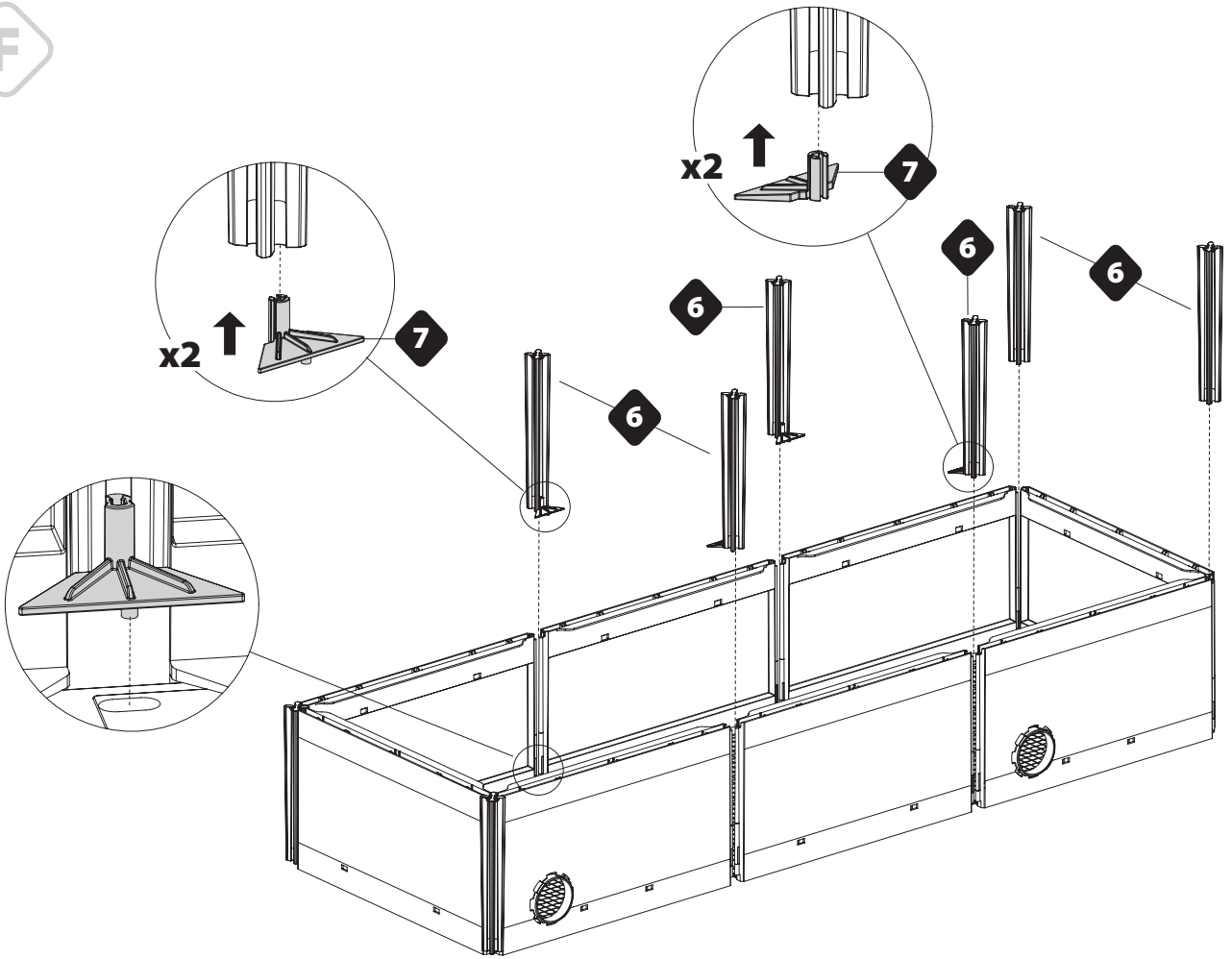

G

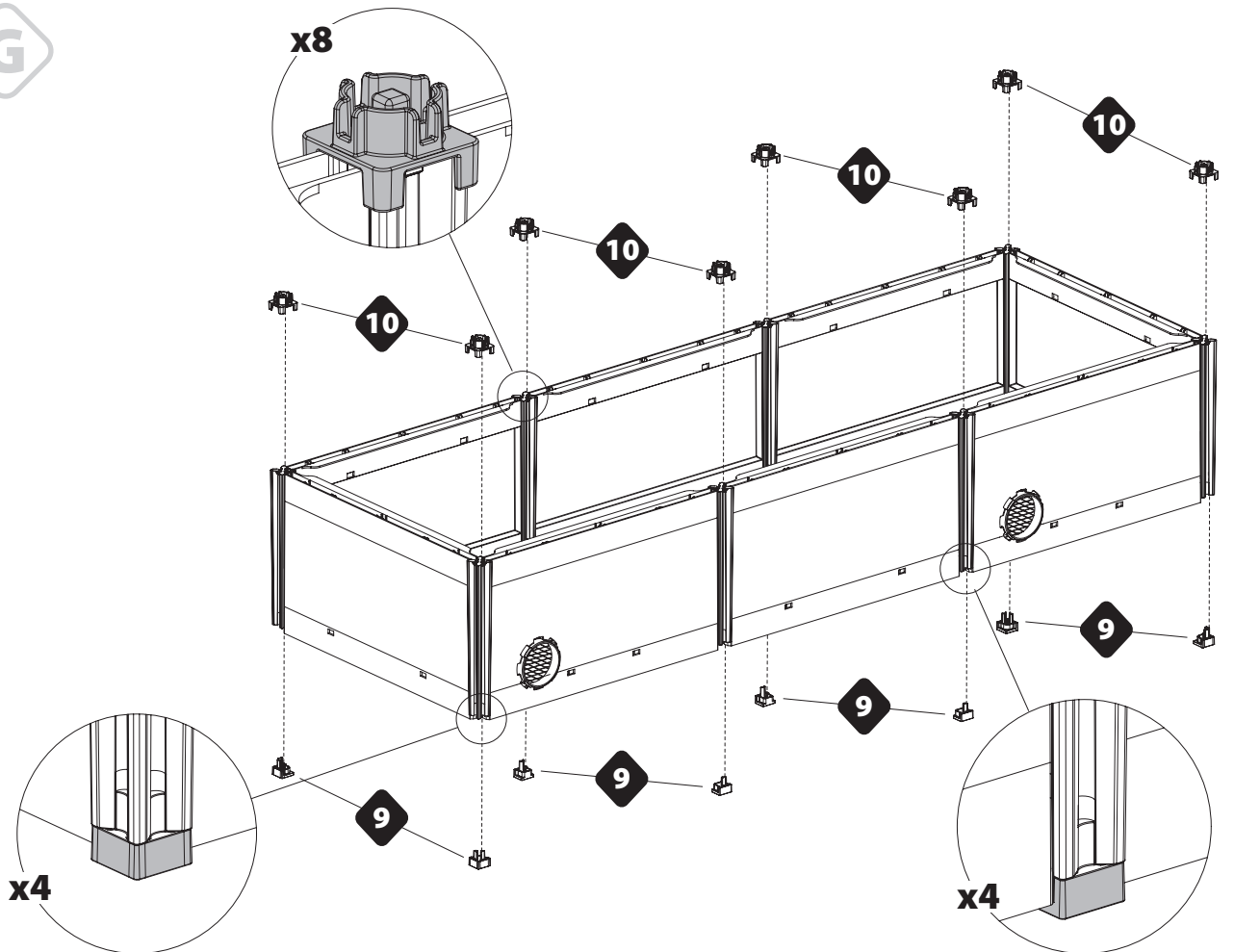

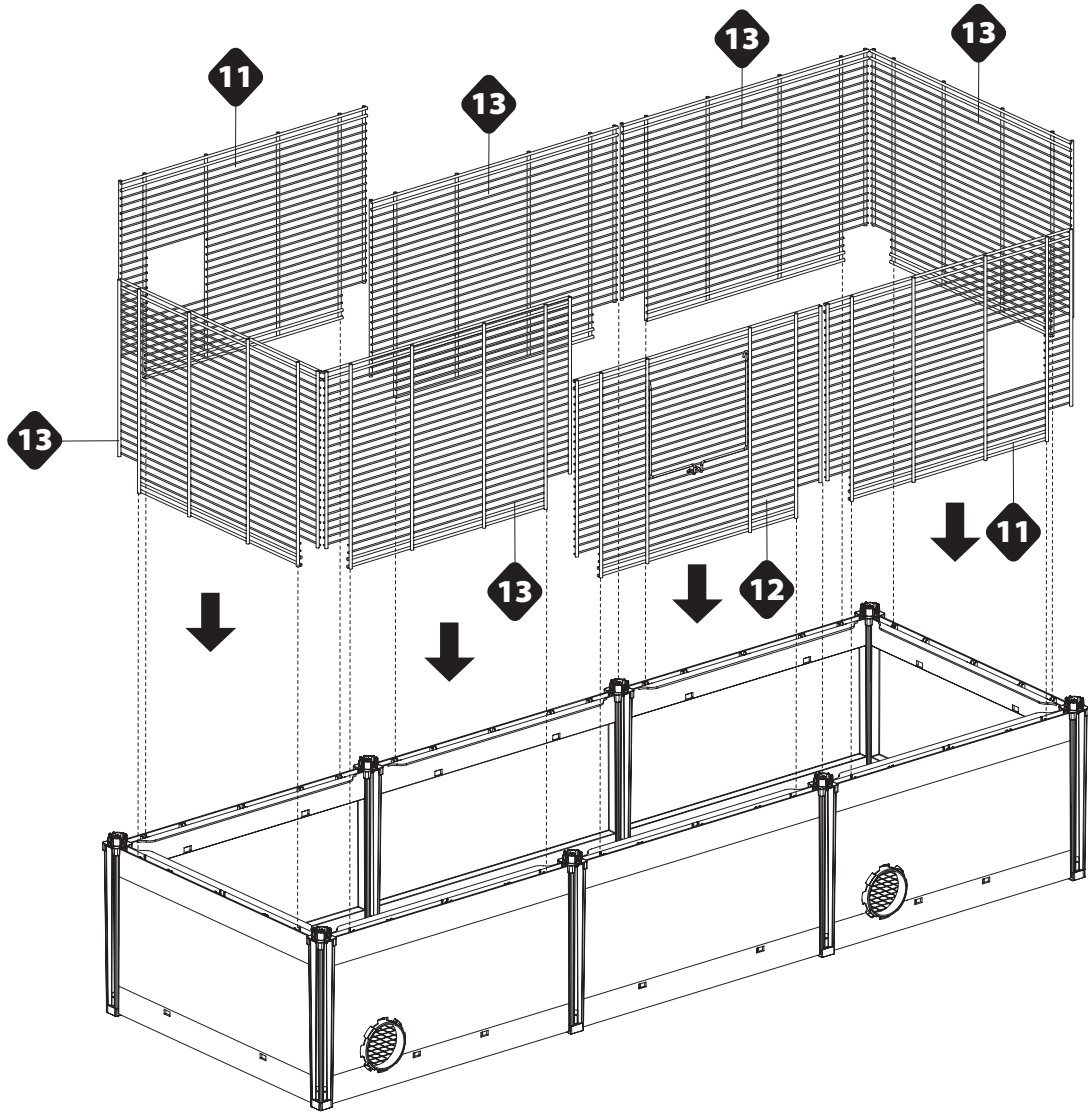

- Place the net so that the vertical bars are in the outer side of the cage.
- Posizionare la rete in modo tale che le barre verticali siano sul lato esterno della gabbia.
- Positionner la grille afin que les barres verticales soient sur le côté extérieur de la cage.
- Bringen Sie das Netz so an, dass sich die vertikalen Stäbe auf der äußeren Seite des Käfigs befinden.
- Plaats het gaas op zo'n manier dat de verticale spijlen aan de buitenkant van de kooi zitten.
- Posicionar la red de modo que las barras verticales estén en el lado externo de la jaula.
- Posicione a grade de modo que as barras verticais fiquem para o lado externo da gaiola.
- Поместите решетку так, чтобы вертикальные стержни находились на внешней стороне клетки.

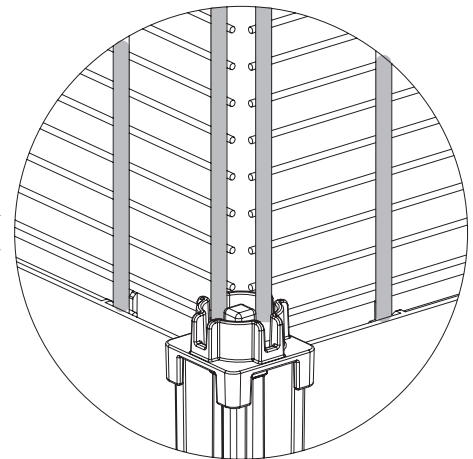

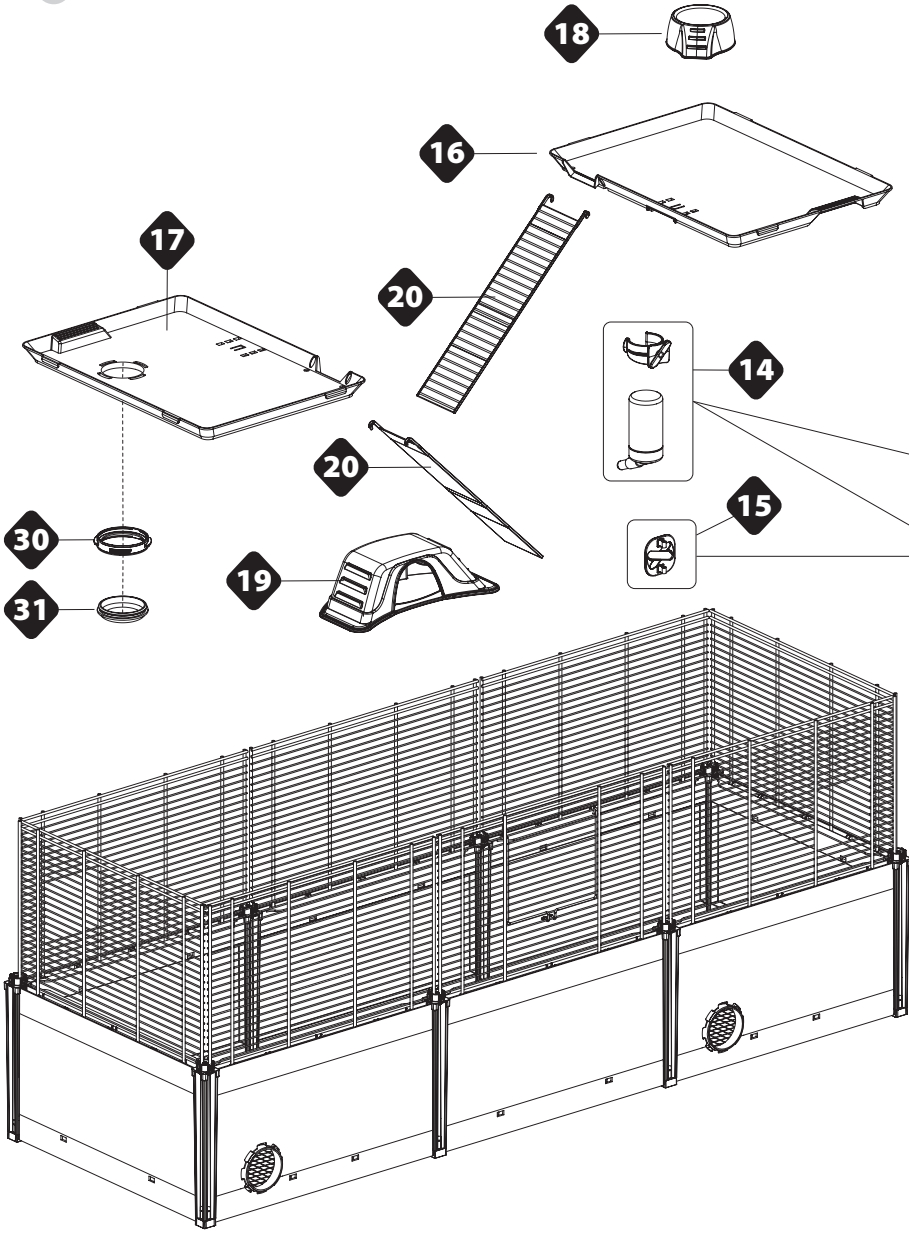

Option 1

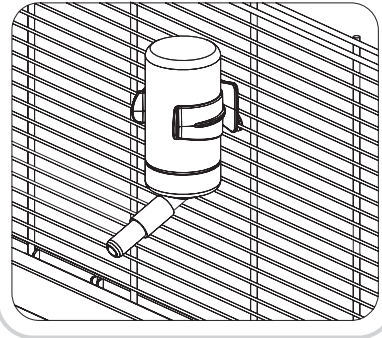
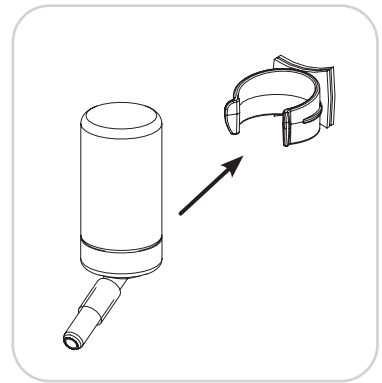
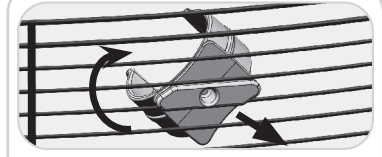

Option 2

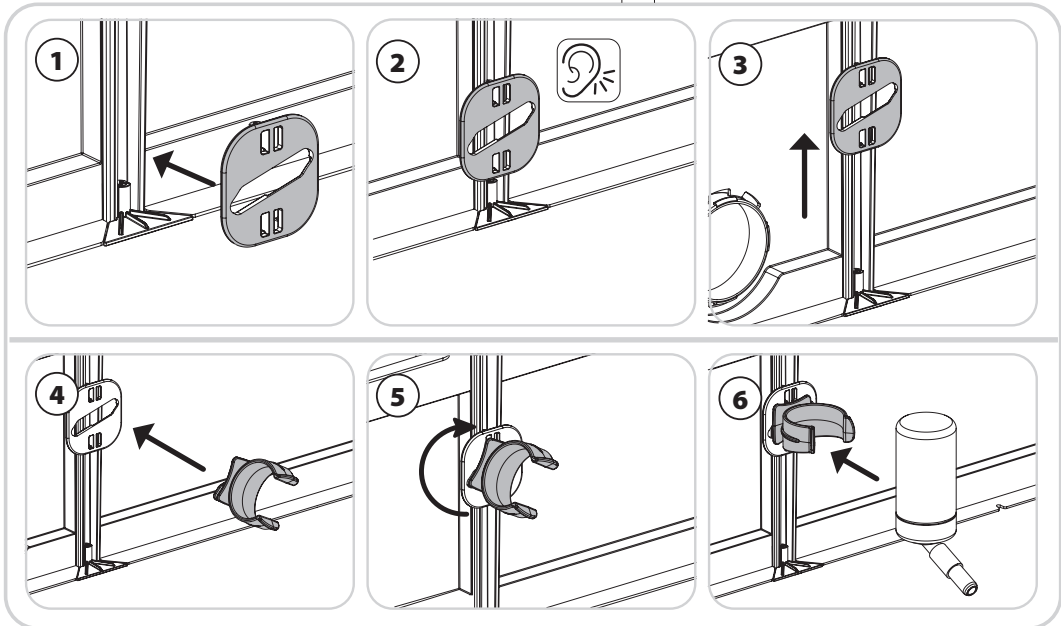

J

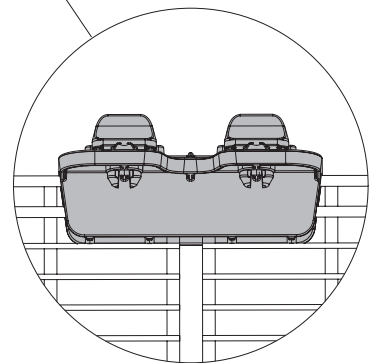
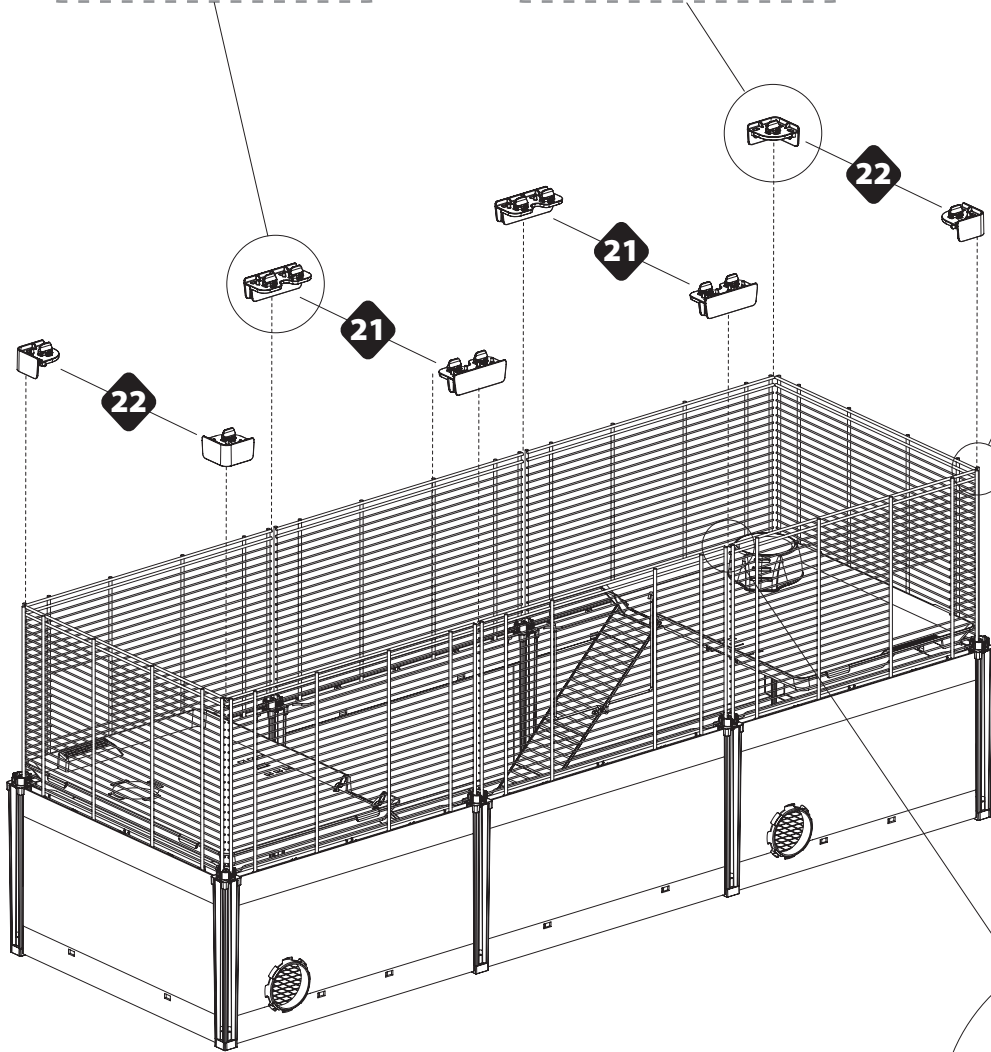
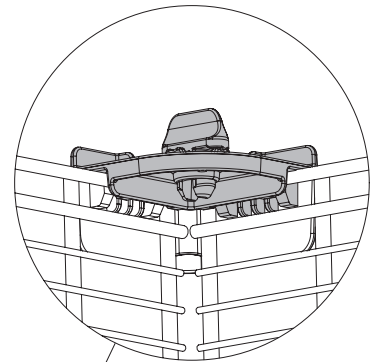
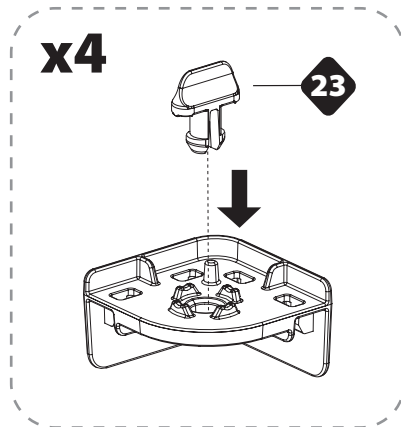
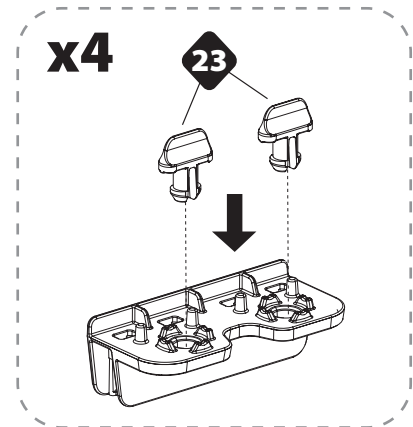

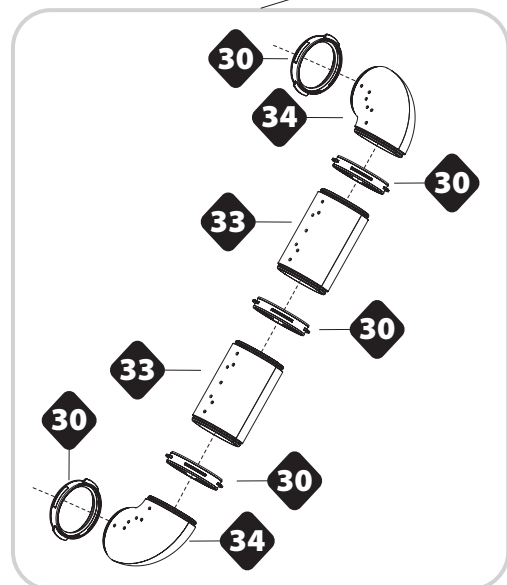
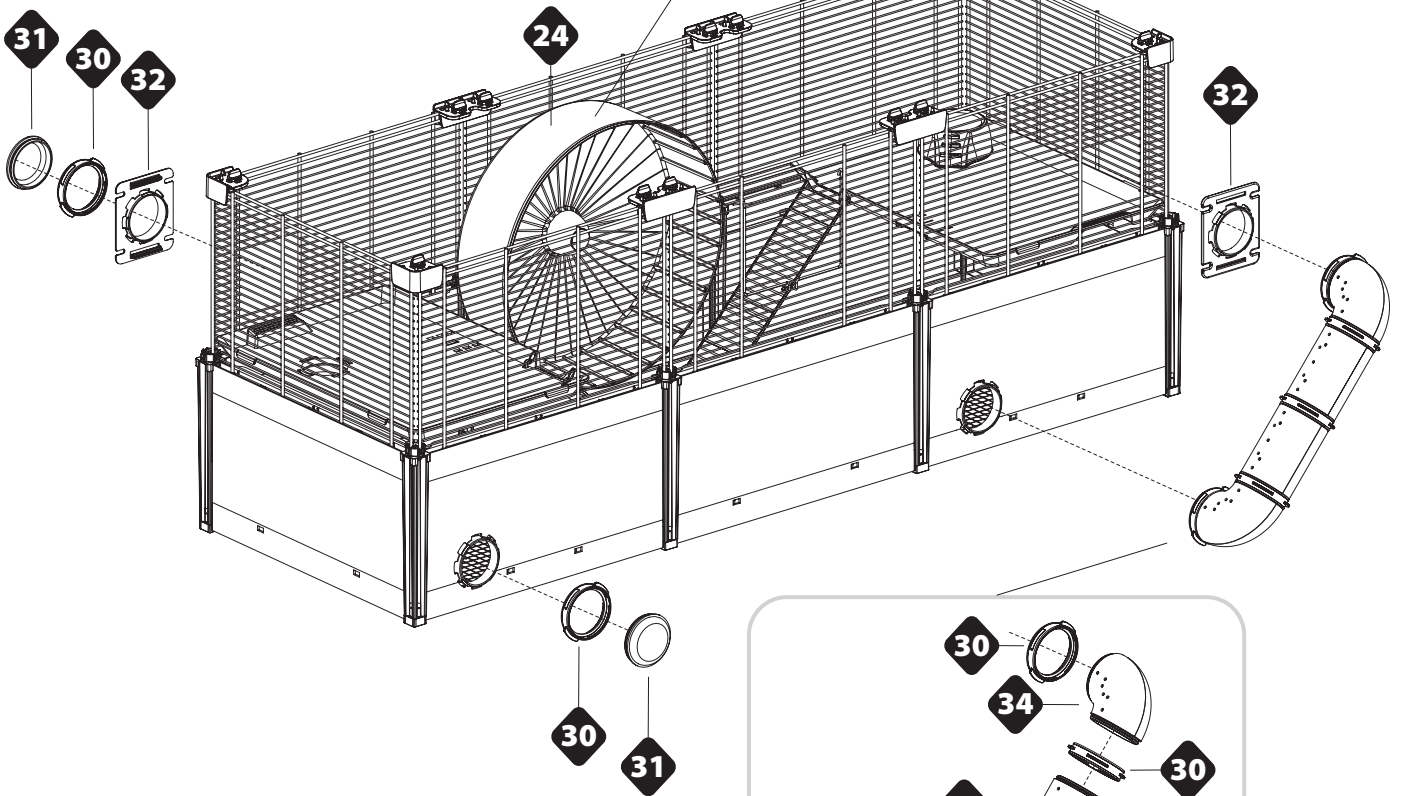
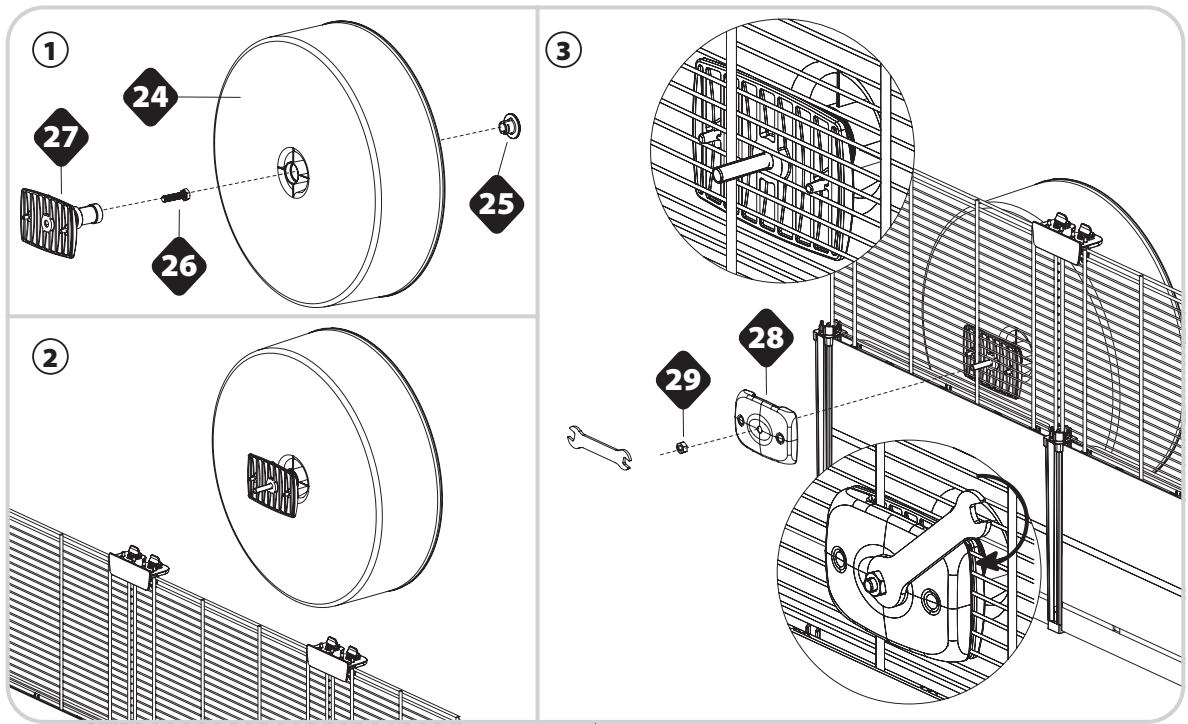

L

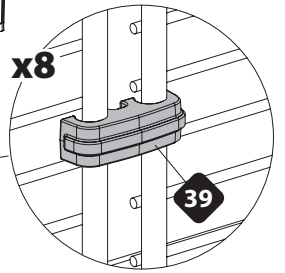
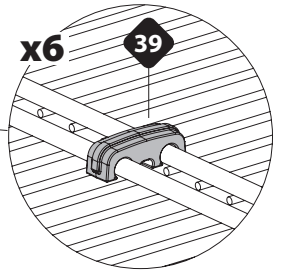
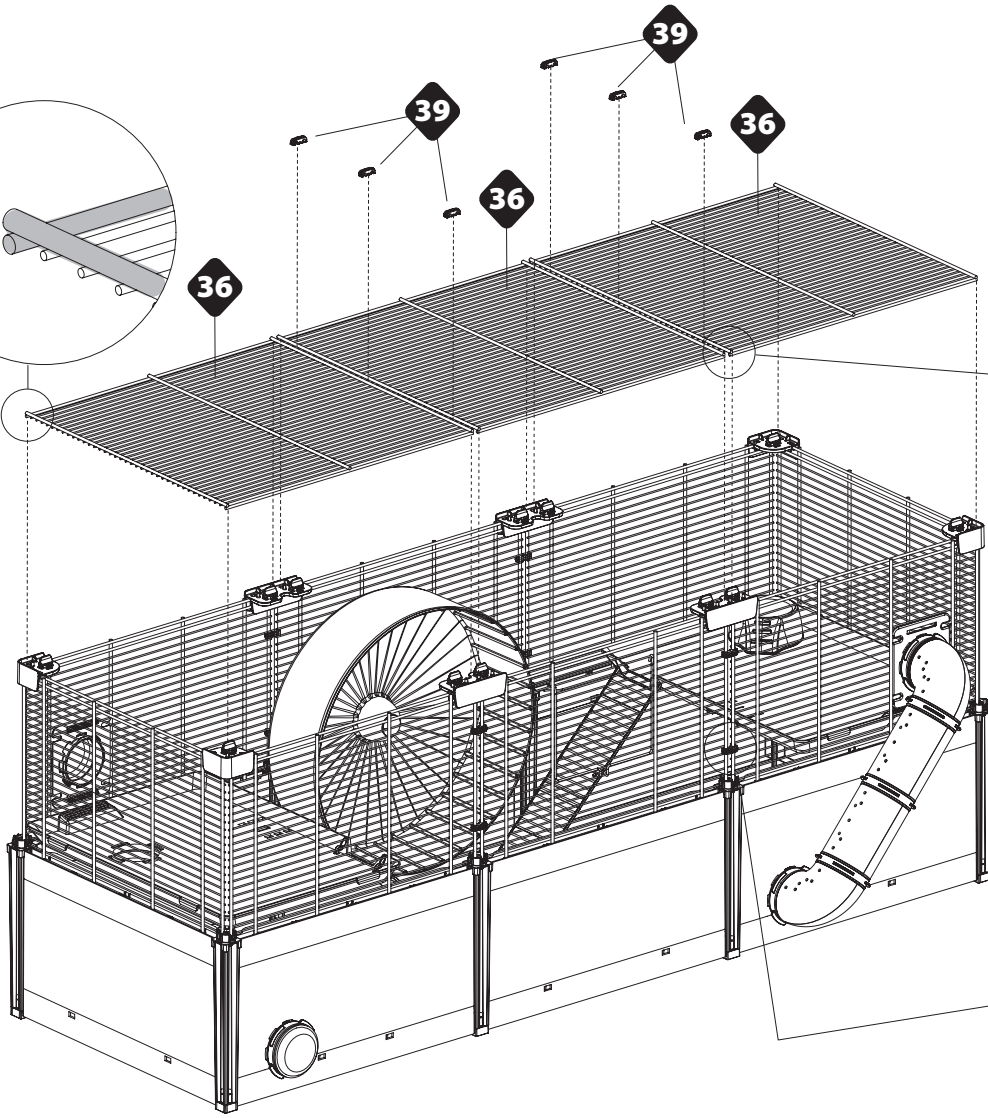

M

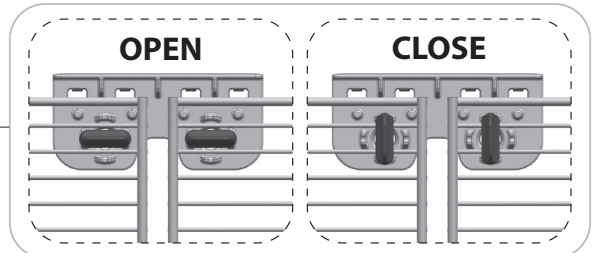
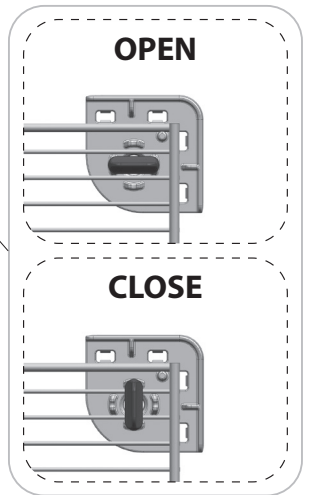
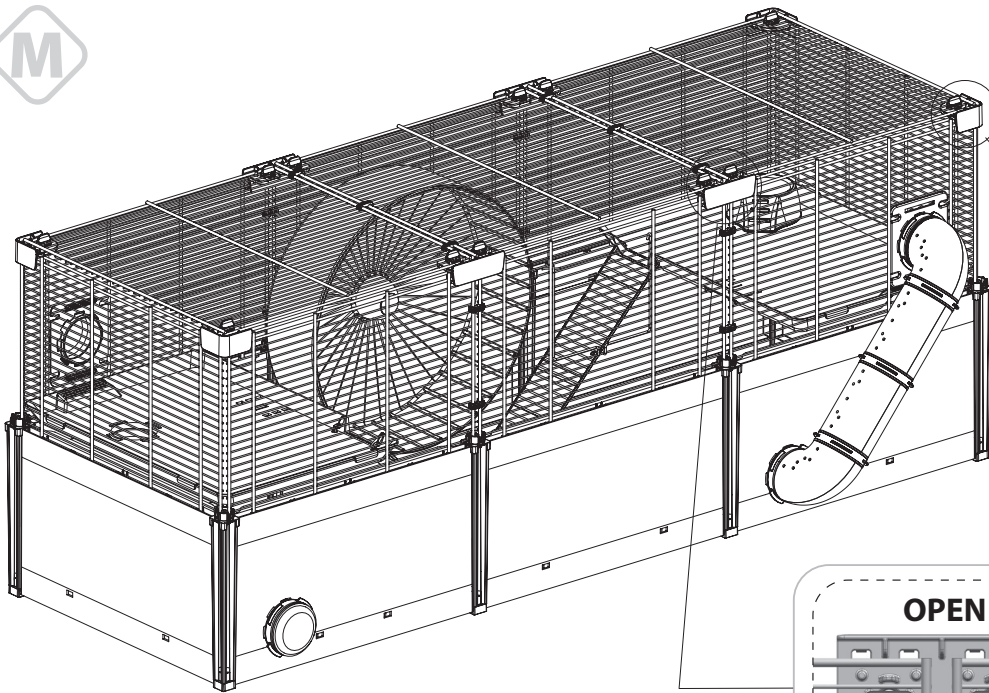

ALTERNATIVE CAGE SET

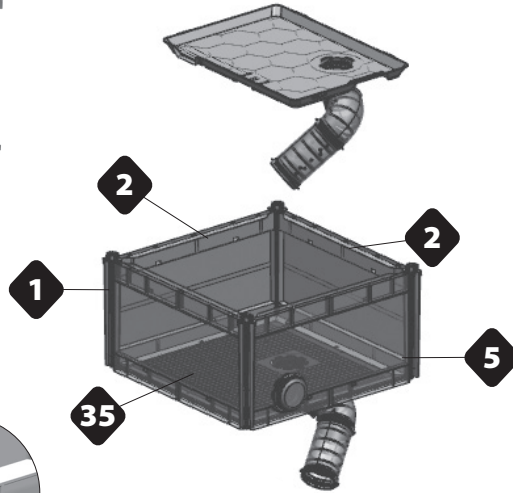
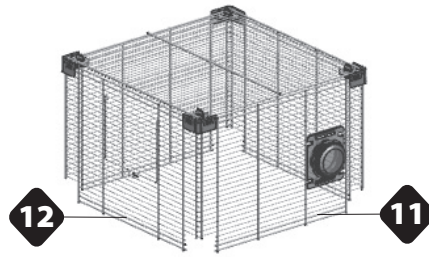
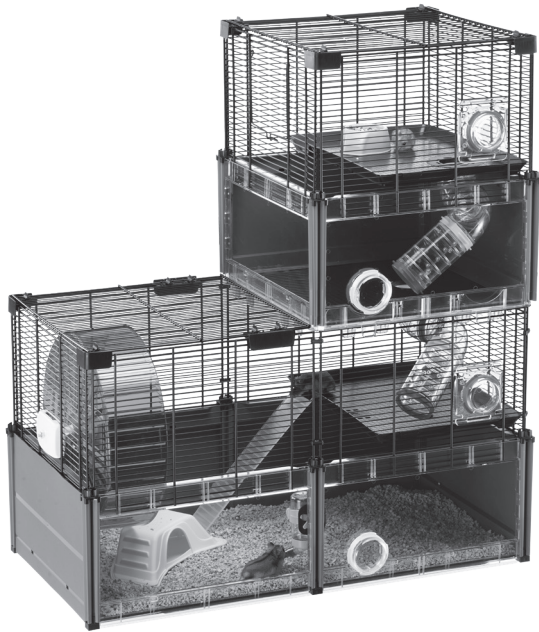

Litter not included.
Lettiera non inclusa.
Litière non incluse.
Streu nicht im Liefer-
umfang enthalten.
Strooisel niet inbegrepen.
Arena no incluída.
Подстилка не включена.

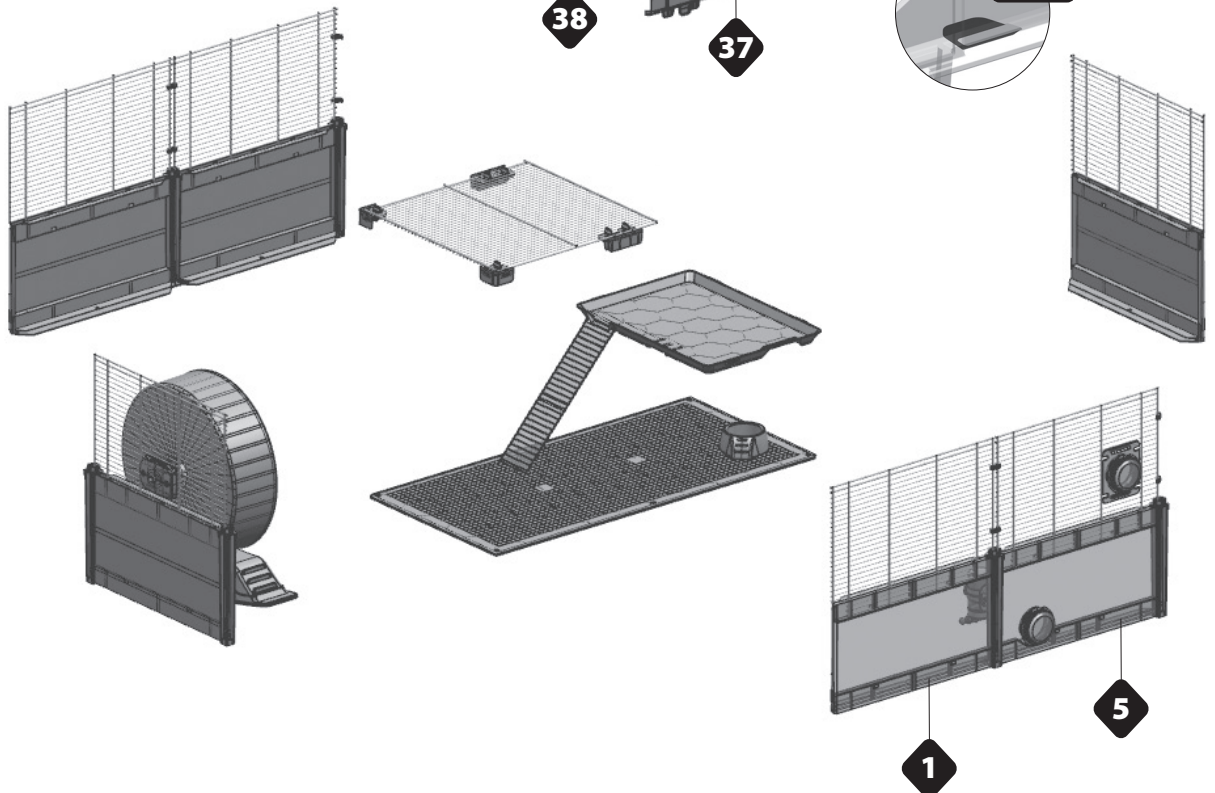
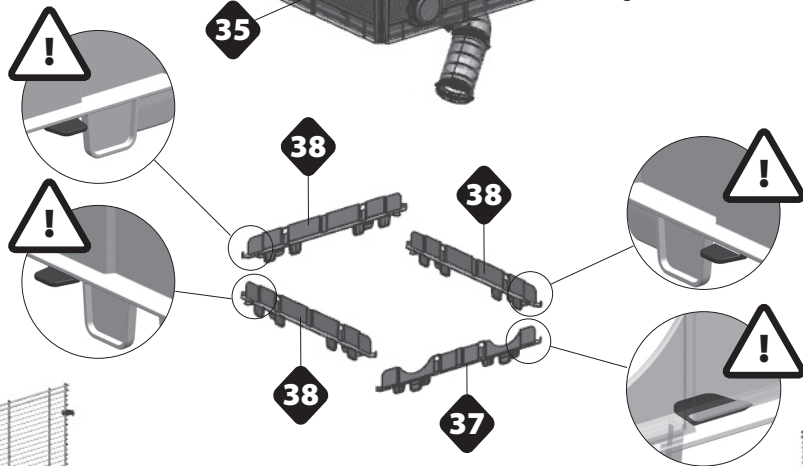

ALTERNATIVE CAGE SET



Litter not included.
Lettiera non inclusa.
Litière non incluse.
Streu nicht im Liefer-
umfang enthalten.
Strooisel niet inbegrepen.
Arena no incluida.
Подстилка не включена.

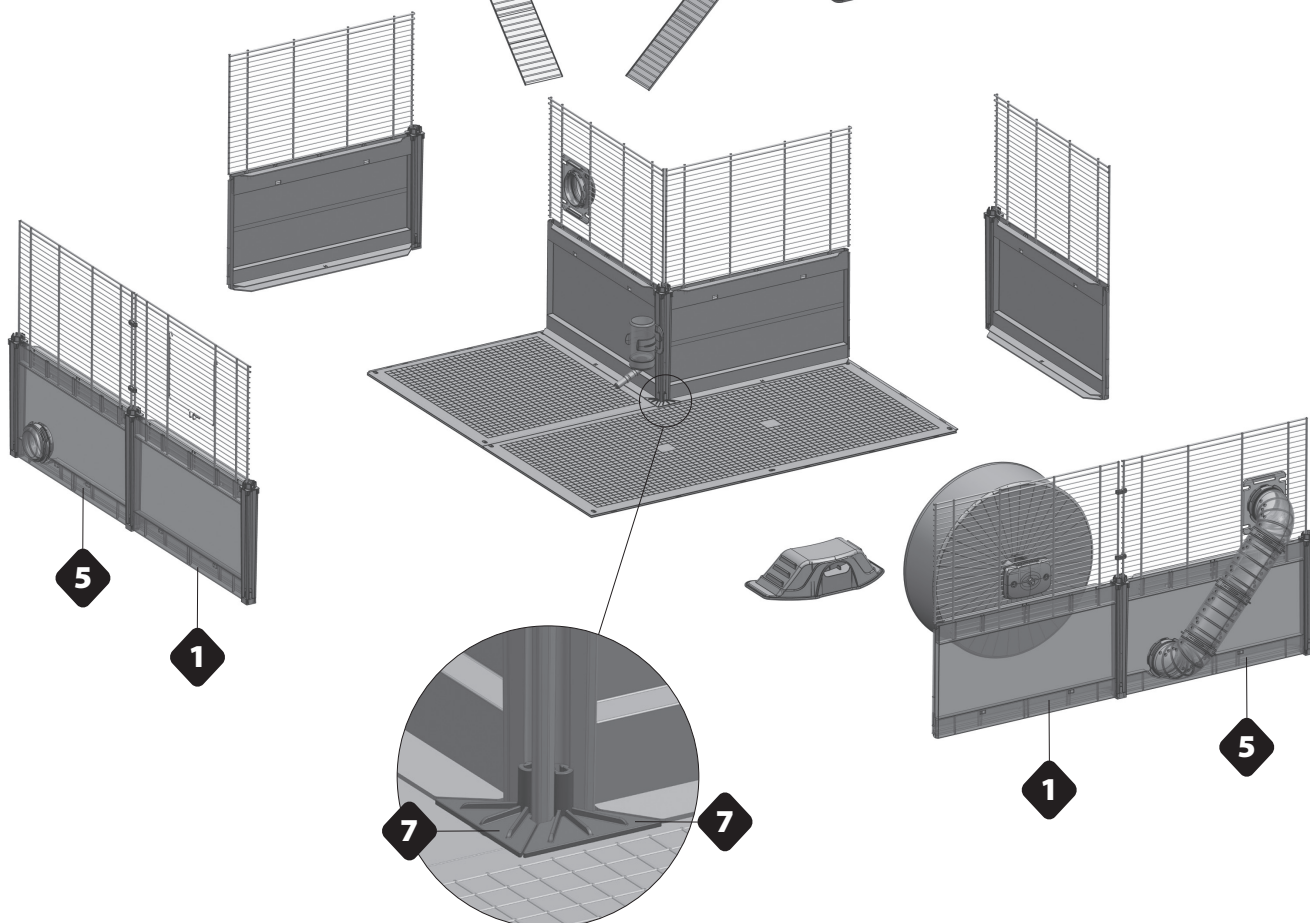
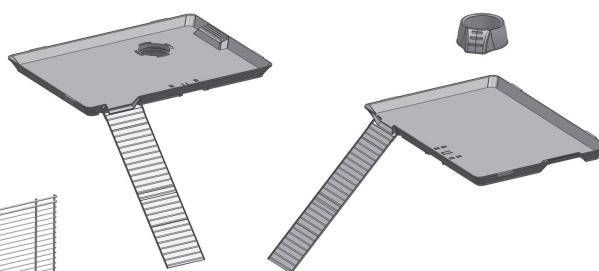
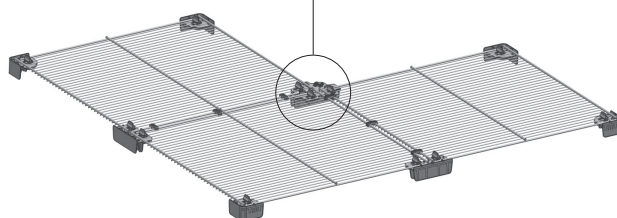
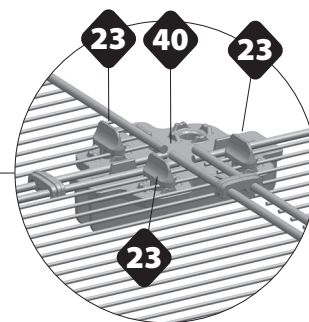



- For better stability and solidity of the cage, fix the walls to the bottom with the supplied screws.
- Per una migliore stabilità e solidità della gabbia fissare le pareti al fondo con le viti in dotazione.
- Pour une meilleure stabilité et solidité de la cage fixer les parois au fond avec les vis fournies.
- Für mehr Stabilität und Festigkeit kann man die Wände mit den mitgelieferten Schrauben am Boden befestigen.

- Voor een goede stabiliteit en stevigheid van de kooi, bevestigt u het beste de wanden aan de bodem met de meegeleverde schroeven.
- Para una mejor estabilidad y solidez de la jaula, fije las paredes al fondo con los tornillos suministrados.
- Para melhor estabilidade e solidez da gaiola, fixe as paredes ao fundo com os parafusos fornecidos.
- Для лучшей устойчивости и прочности каркаса закрепите стенки на дне с помощью прилагаемых винтов.

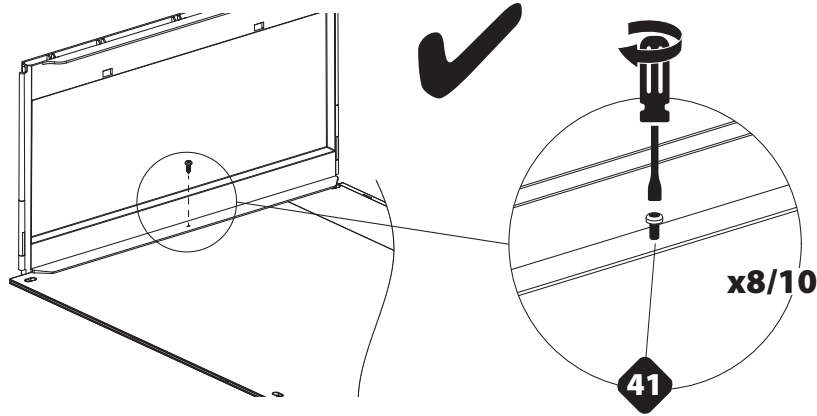

WARNING • ATTENZIONE • AVERTISSEMENT • WARNHINWEISE WAARSCHUWING • ADVERTENCIAS • AVISO • ПРЕДУПРЕЖДЕНИЕ

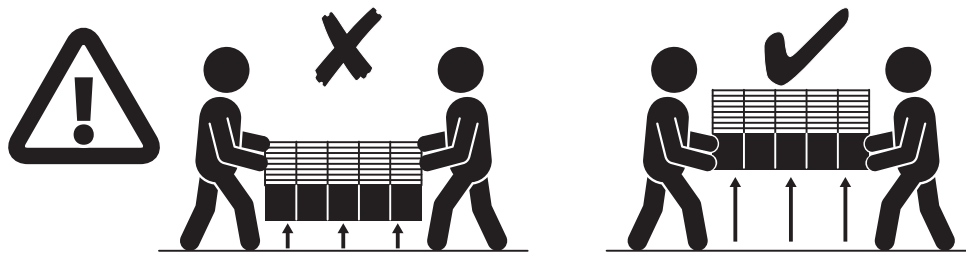

ADD-ON EXTENSION KITS

Make your Favourite Home Set
Crea la tua configurazione preferita
Construisez votre KIT d'Habitat préféré
Entwirf und baue Dein modulares Traumheim
Maak je favoriete verblijf
Crea tu set de hogar favorito
Faça sua montagem preferida
Построй свой любимый дом

