

Montageanleitung / Instructions for assembly / Istruzioni di montaggio / Guide de montage

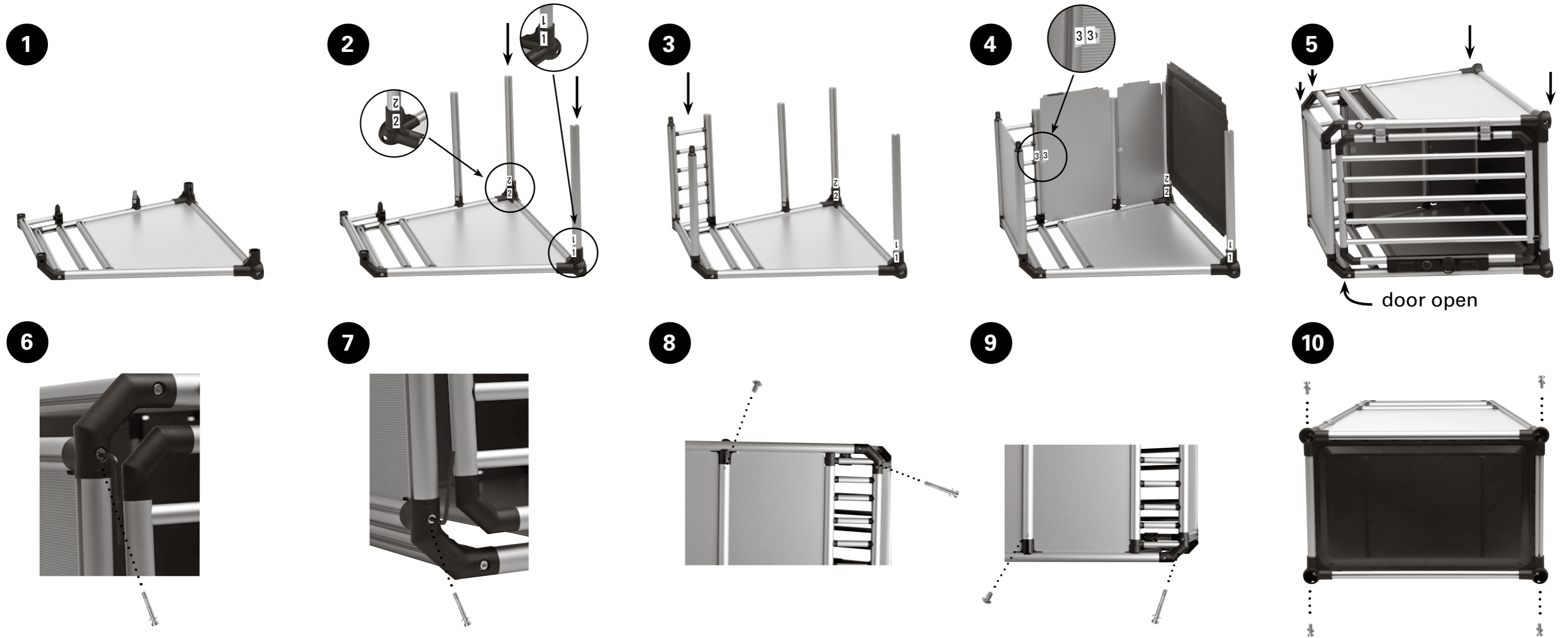

How to switch the door

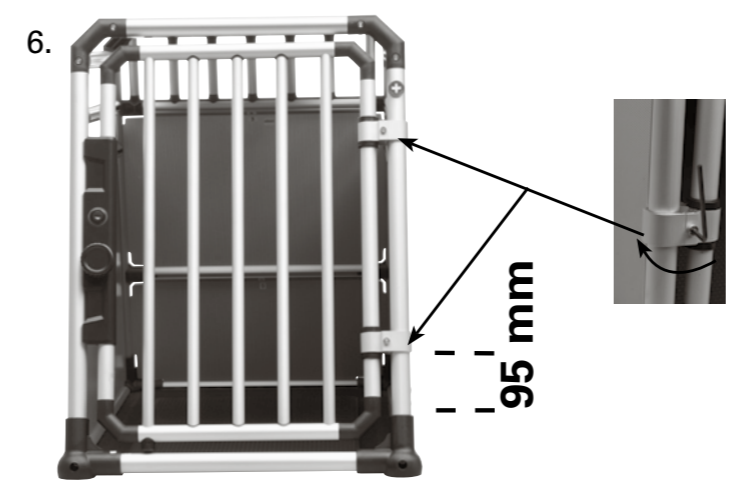
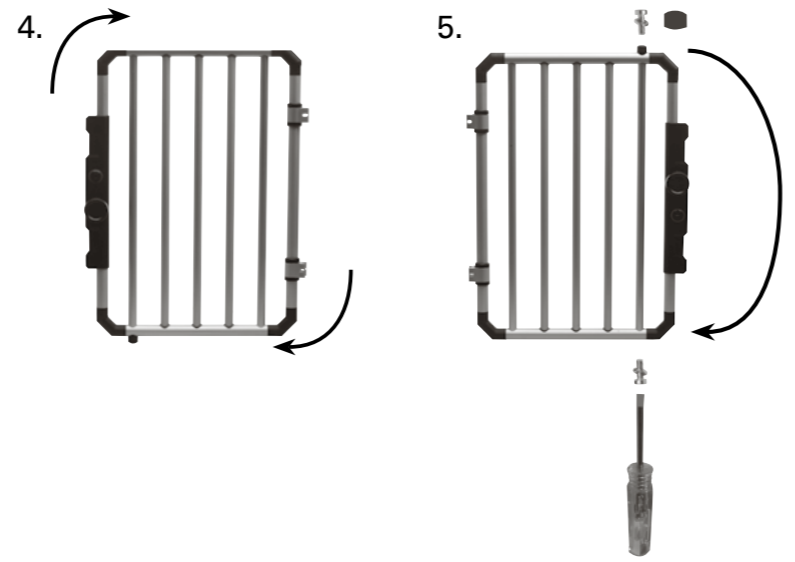
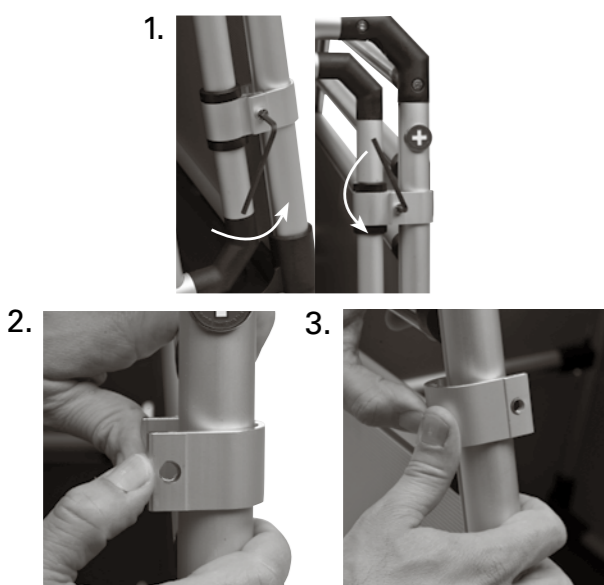

Door adjustment

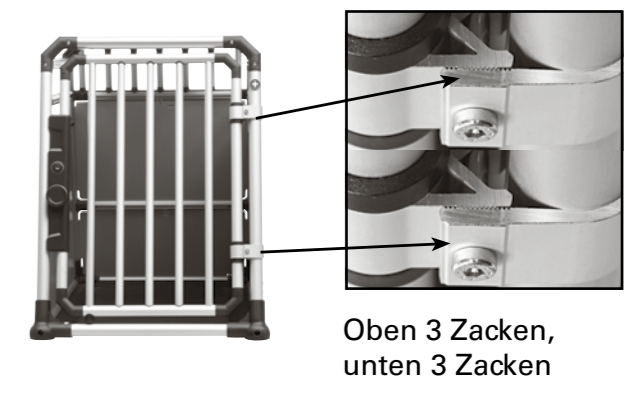

Lieferumfang / Scope of supply / Volume della fornitura / Etendue des fournitures



1



2



3



4

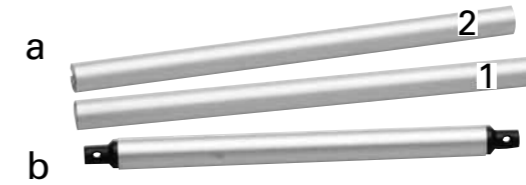

5



6

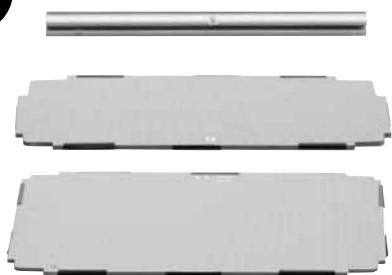

7



8



9



10



11



D

- 1 Seitenwand links
- 2 Seitenwand rechts
- 3 Bodenelement
- 4a Zwei nummerierte Bodenprofilrohre (vorne und hinten)
- 4b Dachverbinder (vorne)
- 5 Dachelement
- 6 Rückwandelemente
- 7 Vier lange Schrauben mit Scheiben
- 8 Vier kurze Schrauben mit Scheiben
- 9 Zwei Linsenschrauben
- 10 Inbusschlüssel (2x)
- 11 Hersteller-Dokumentation

E

- 1 Side wall left
- 2 Side wall right
- 3 Floor element
- 4a Two numbered floor profile tubes (front and rear)
- 4b Roof connector (front)
- 5 Roof element
- 6 Rear wall
- 7 Four long screws with washers
- 8 Four short screws with washers
- 9 Two lens screws
- 10 Allen key (2x)
- 11 Manufacturer documentation

I

- 1 Parete laterale sinistra
- 2 Parete laterale destra
- 3 Elemento del pavimento
- 4a Due tubi profilati per il pavimento numerati (davanti e dietro)
- 4b Elemento di collegamento del tetto (davanti)
- 5 Elemento del tetto
- 6 Parete posteriore
- 7 Quattro viti lunghe con rondelle
- 8 Quattro viti corte con rondelle
- 9 Due viti con testa a bottone
- 10 Chiave a brugola (2x)
- 11 Documentazione fabbricante

F

- 1 Paroi latérale gauche
- 2 Paroi latérale droite
- 3 Paroi inférieure
- 4a Deux tubes profilés et numérotés pour la paroi inférieure (avant et arrière)
- 4b Élément d'assemblage paroi supérieure (avant)
- 5 Paroi supérieure
- 6 Paroi arrière
- 7 Quatre vis longues avec rondelles
- 8 Quatre vis courtes avec rondelles
- 9 Deux vis à tête bombée
- 10 Clé à six pans (2x)
- 11 La documentation fabricante

