

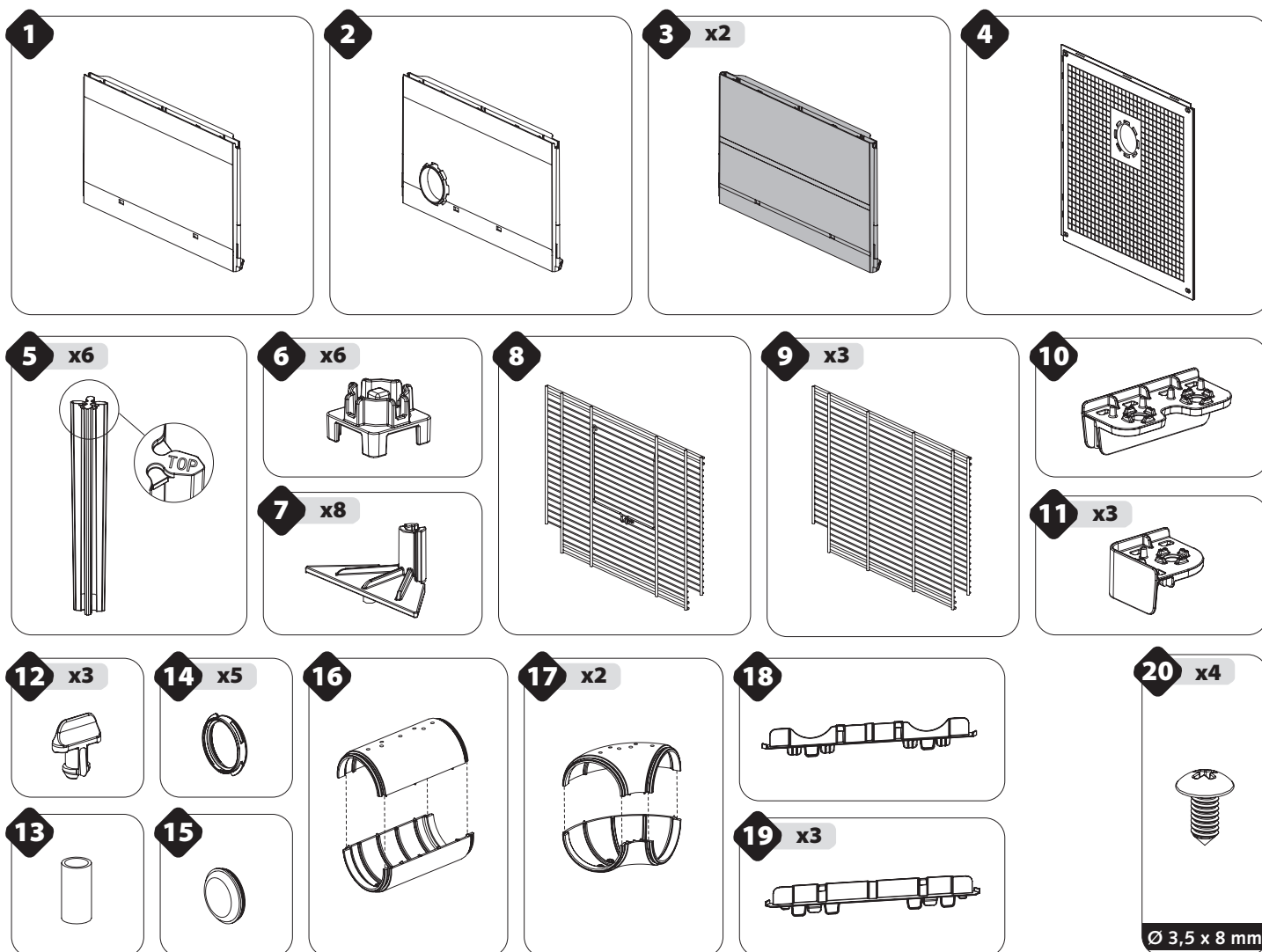

Cod. 57008017

375 x 375 x h 410 mm

14.76 x 14.76 x h 16.14 in



A

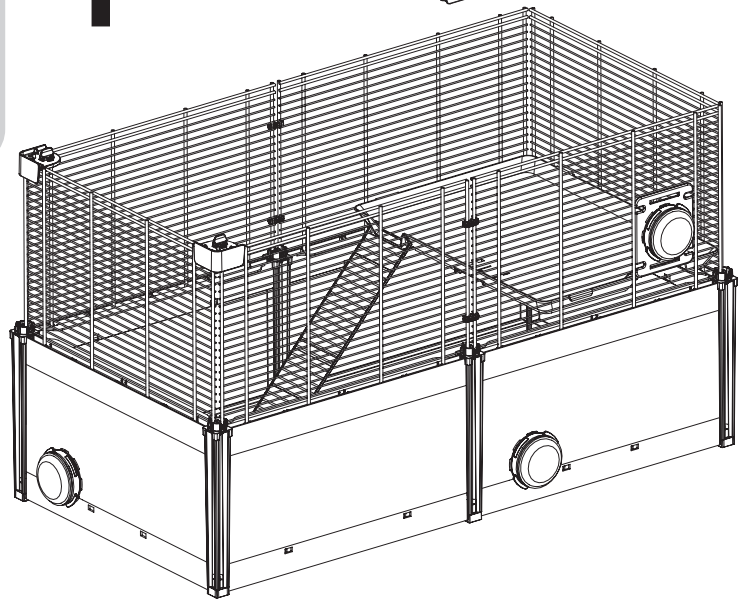
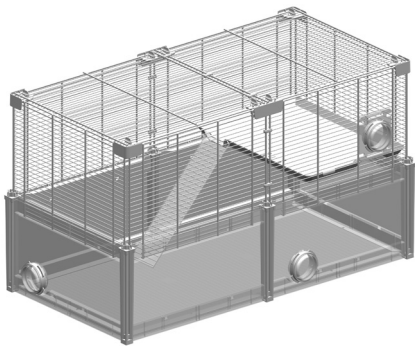
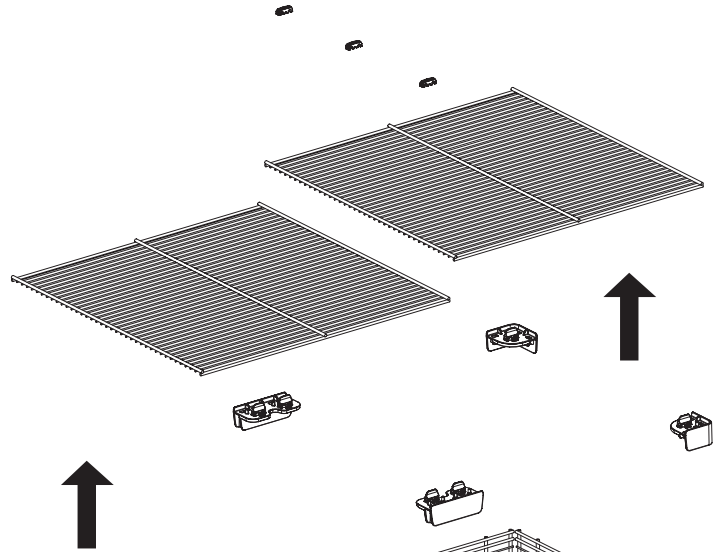
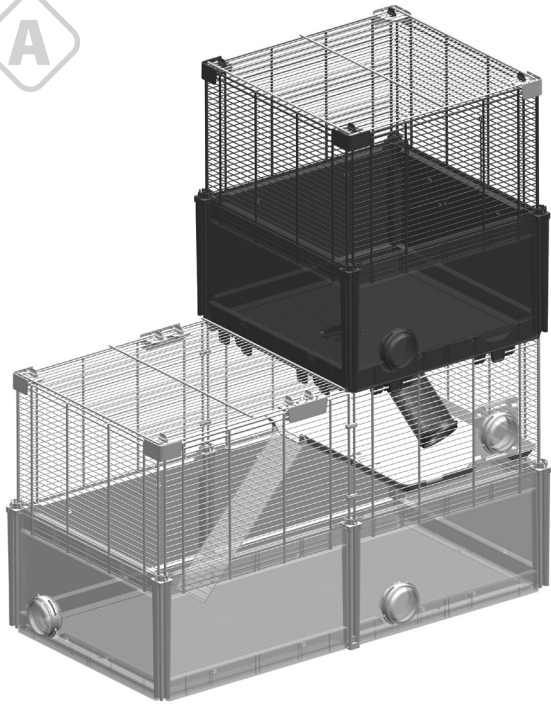

B

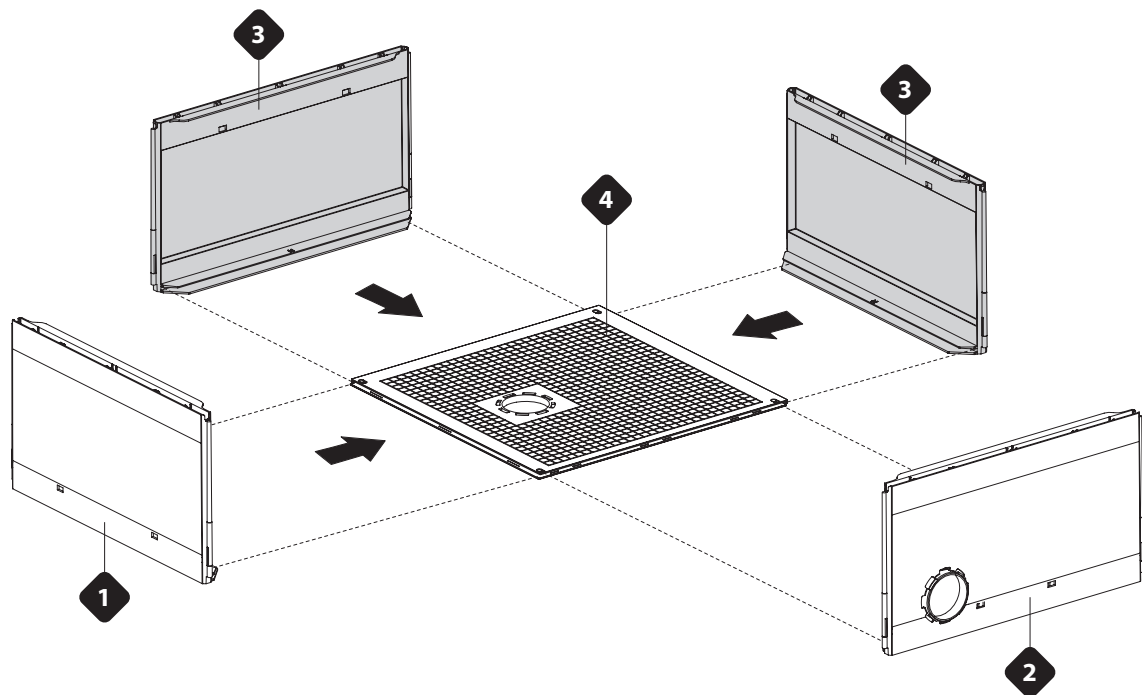

C

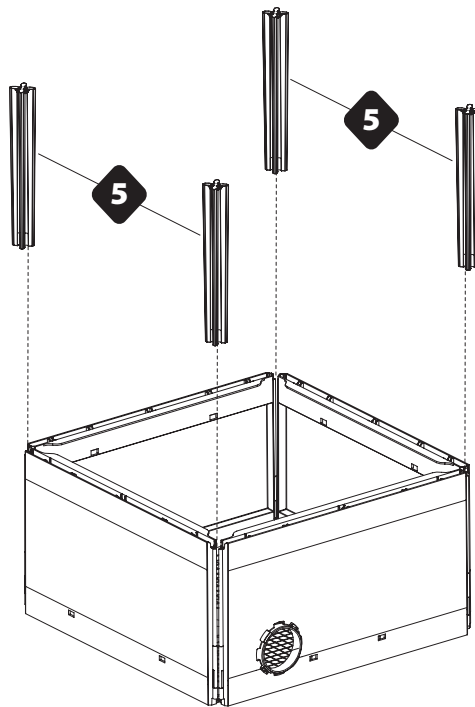

D

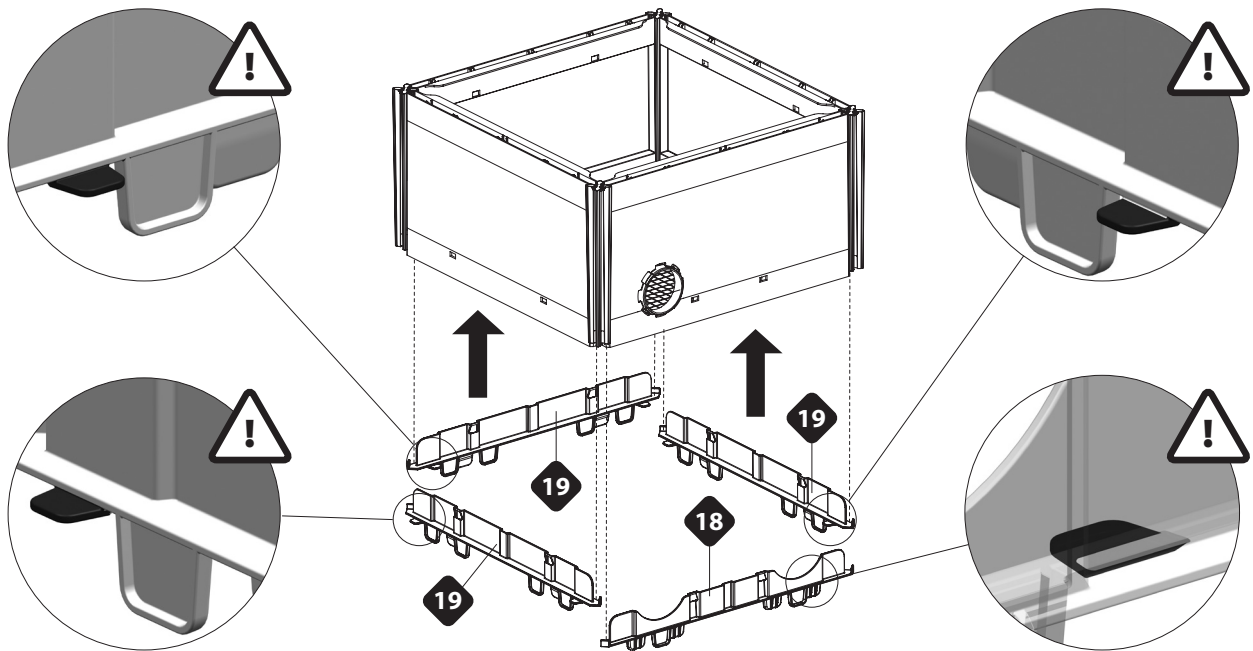

E

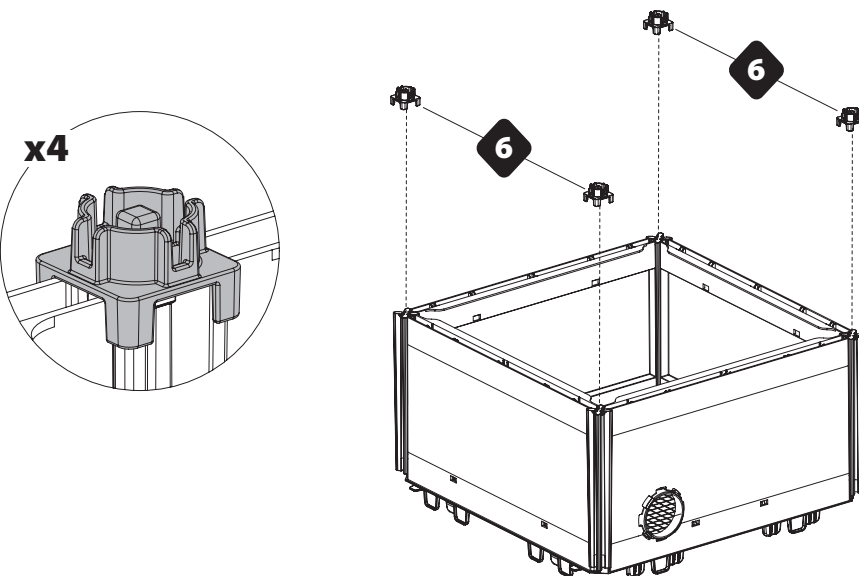

**F**

- Place the net so that the vertical bars are in the outer side of the cage.
- Posizionare la rete in modo tale che le barre verticali siano sul lato esterno della gabbia.
- Positionner la grille afin que les barres verticales soient sur le côté extérieur de la cage.
- Bringen Sie das Netz so an, dass sich die vertikalen Stäbe auf der äußeren Seite des Käfigs befinden.
- Plaats het gaas op zo'n manier dat de verticale spijlen aan de buitenkant van de kooi zitten.
- Posicionar la red de modo que las barras verticales estén en el lado externo de la jaula.
- Posicione a grade de modo que as barras verticais fiquem para o lado externo da gaiola.
- Поместите решетку так, чтобы вертикальные стержни находились на внешней стороне клетки.

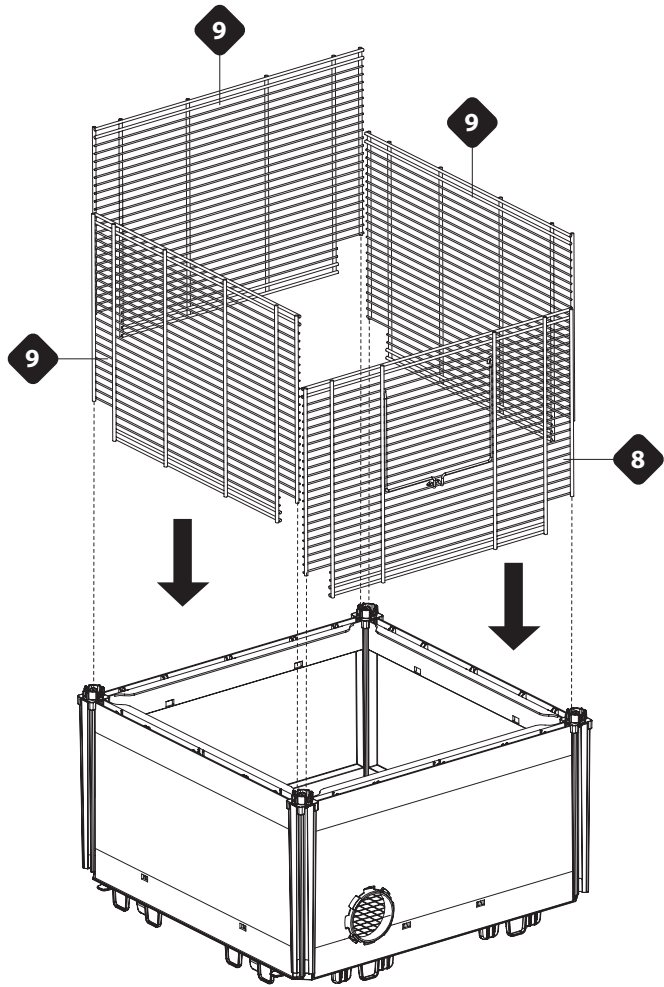
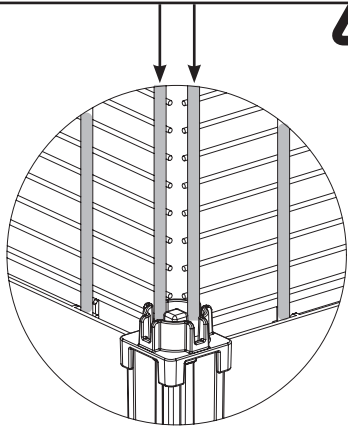
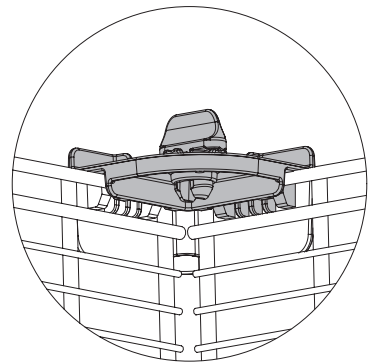
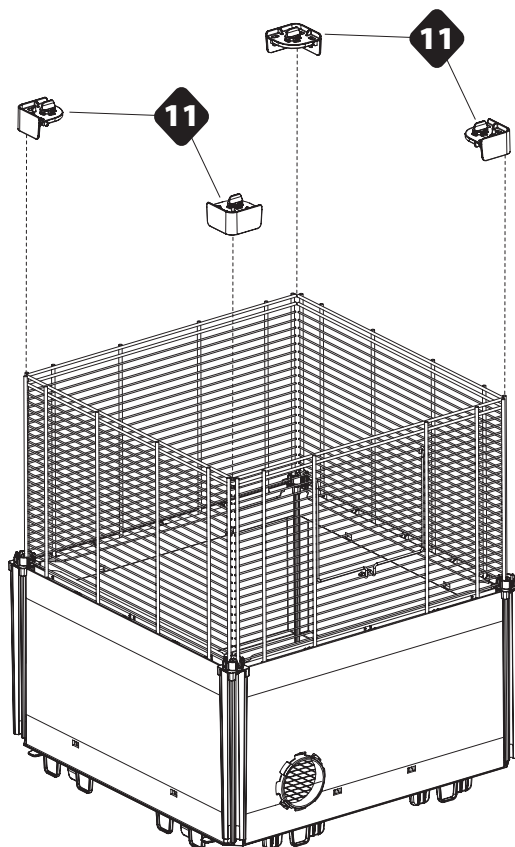
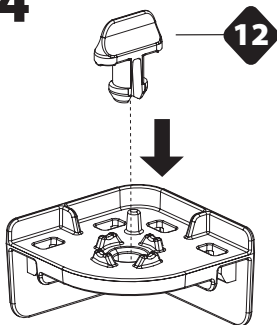
**G****x4**



H

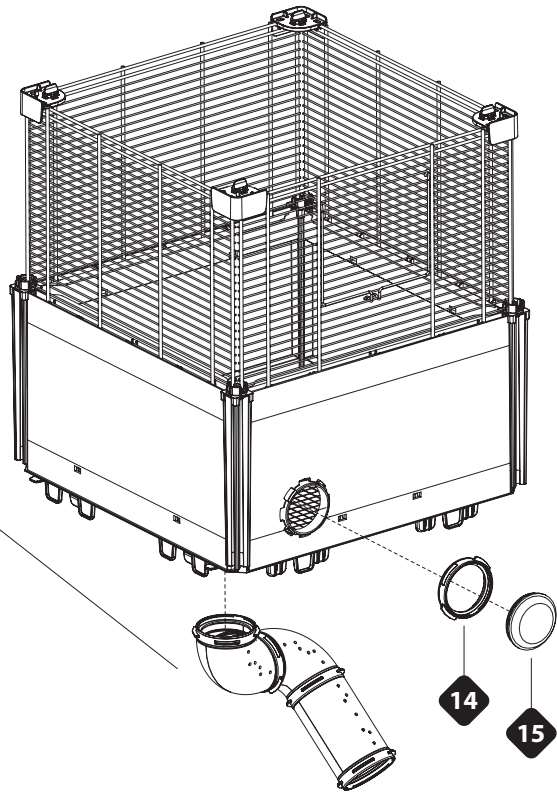
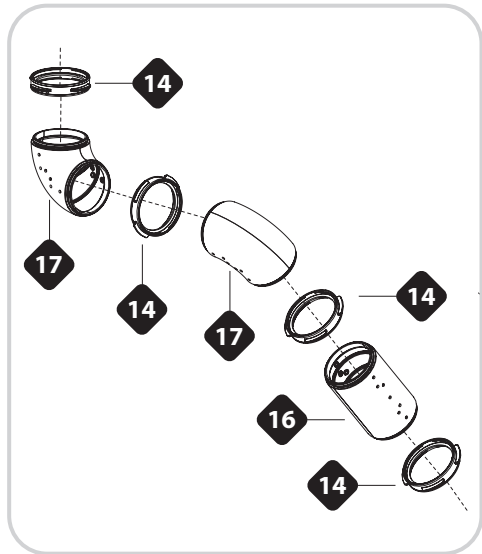

I

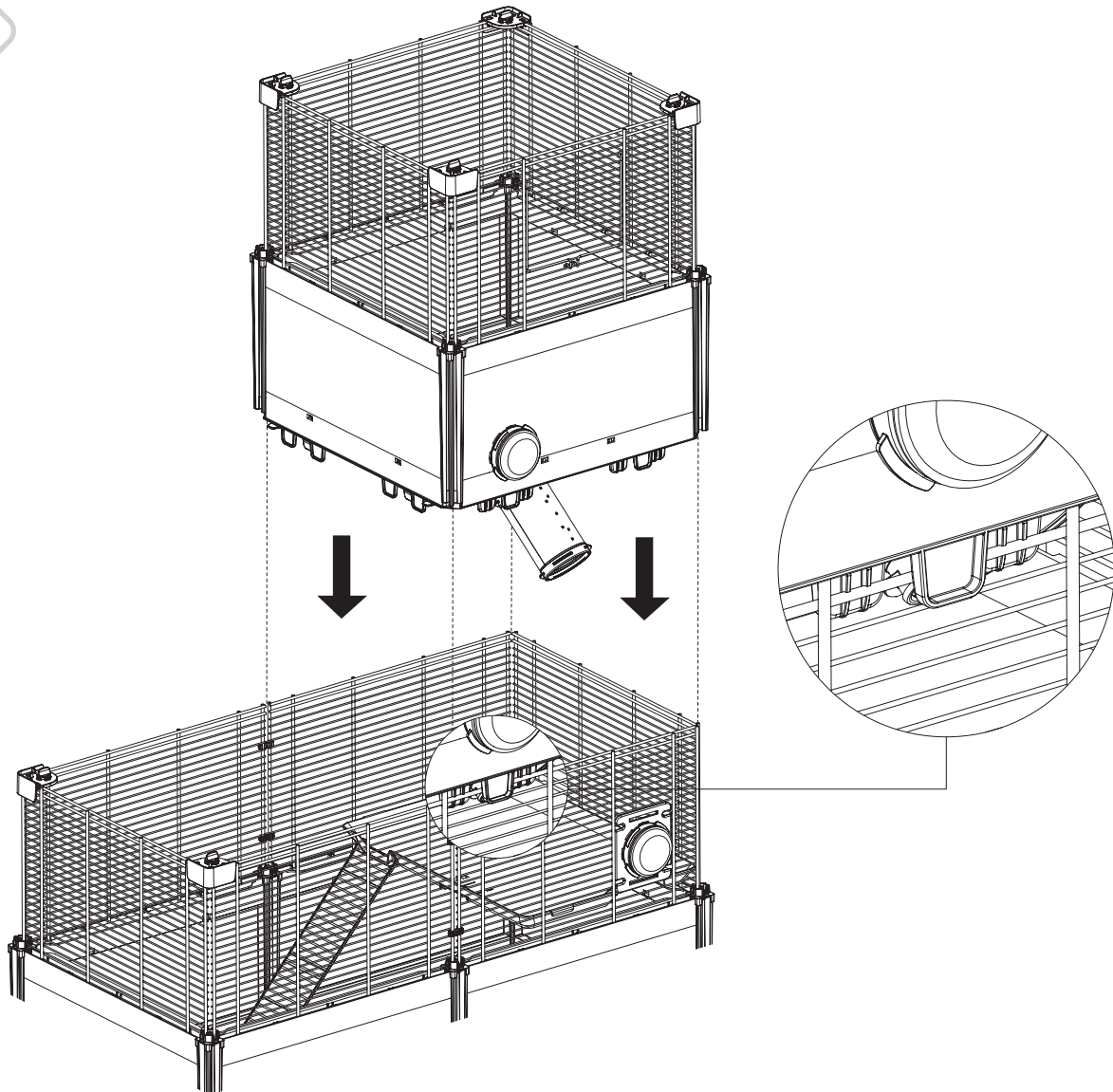

J

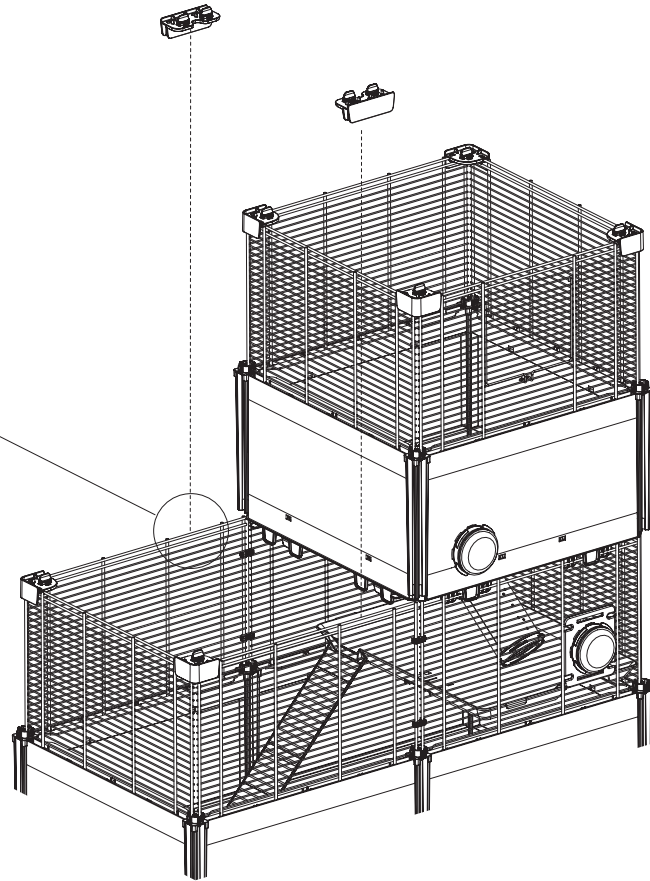
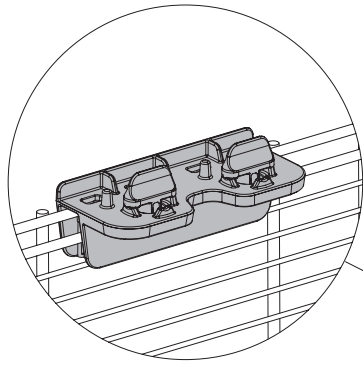

K

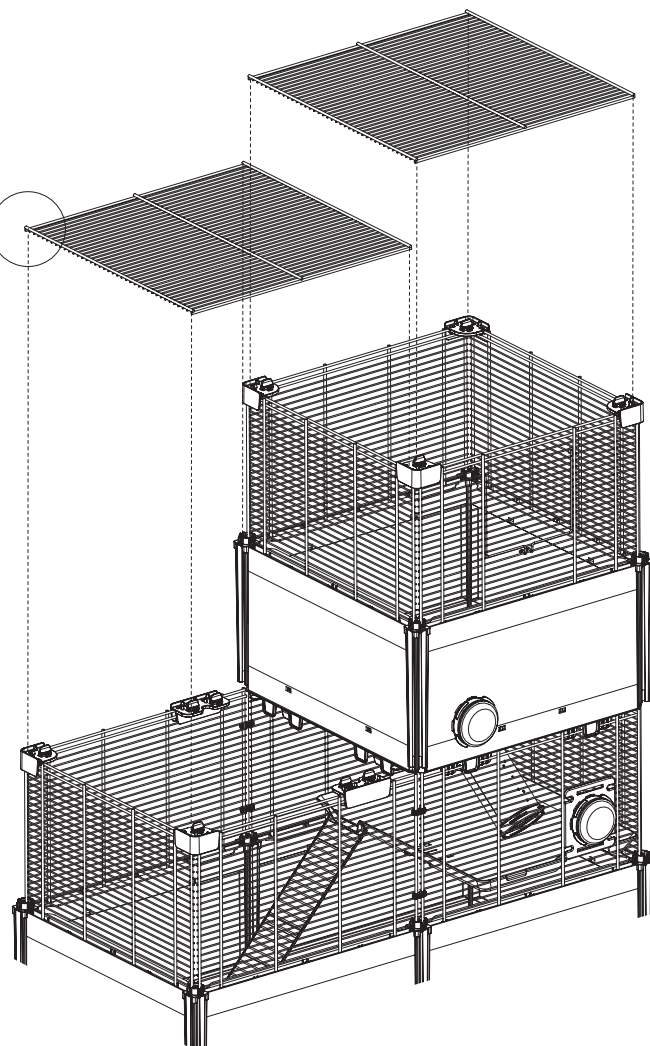
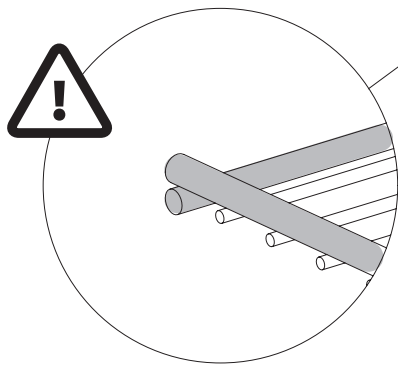

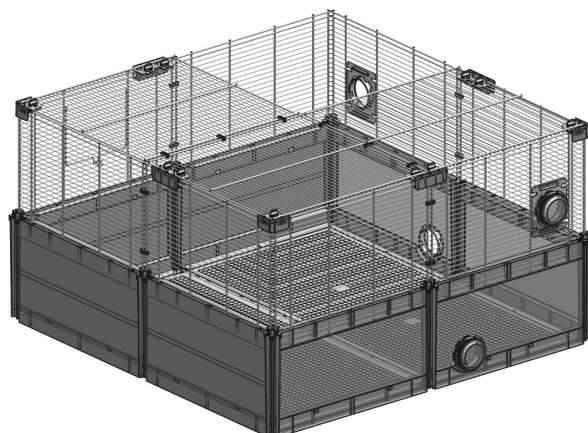
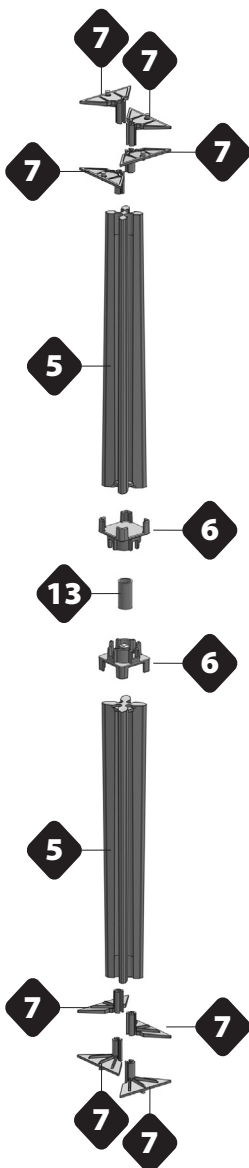
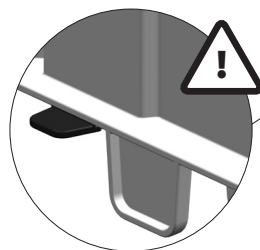
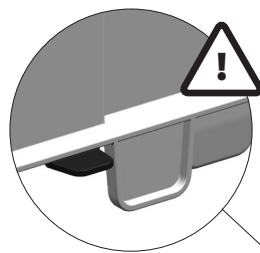
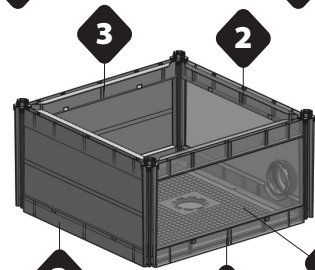
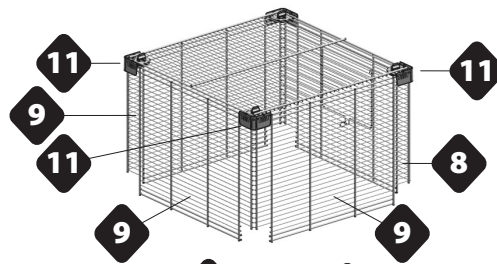
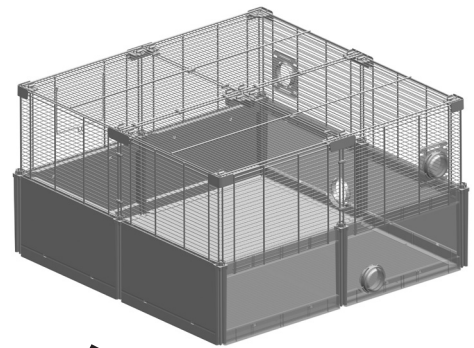
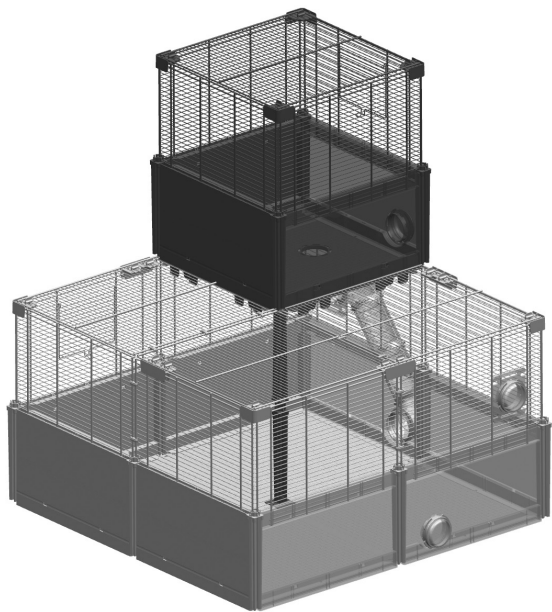



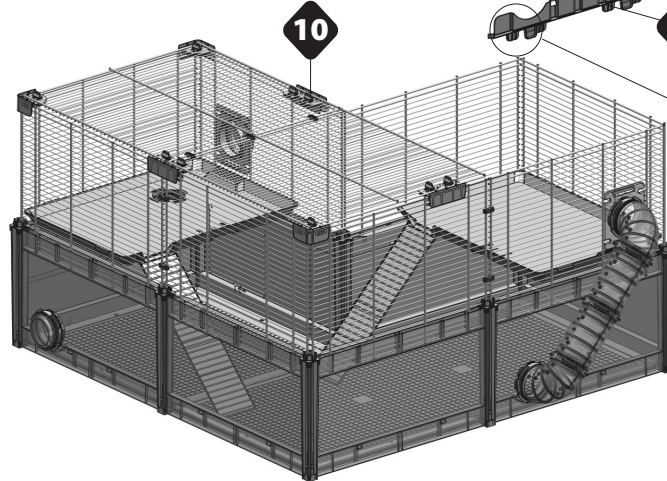
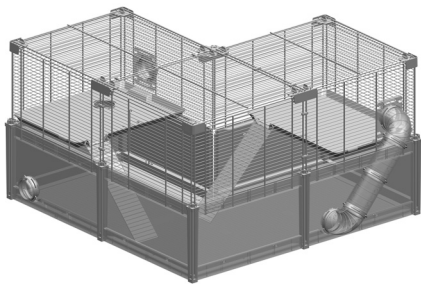
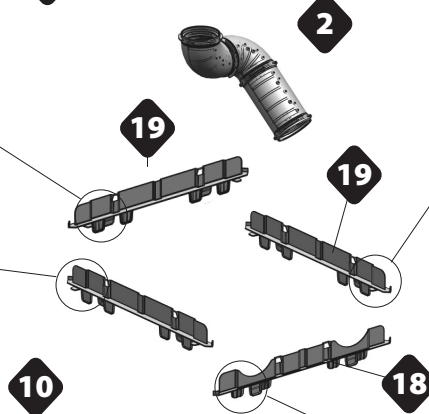
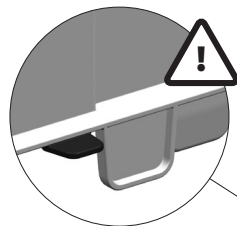
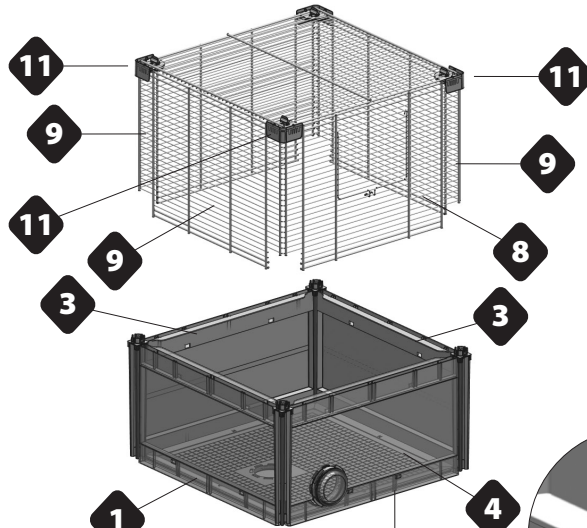
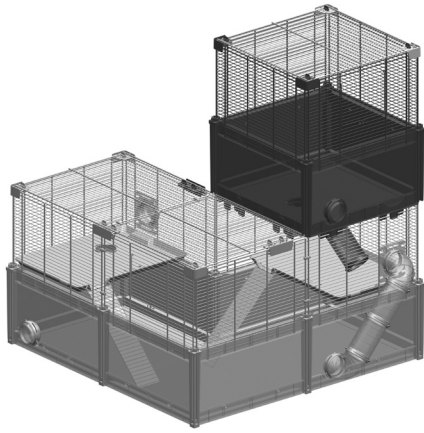

- For better stability and solidity of the cage, fix the walls to the bottom with the supplied screws.
- Per una migliore stabilità e solidità della gabbia fissare le pareti al fondo con le viti in dotazione.
- Pour une meilleure stabilité et solidité de la cage fixer les parois au fond avec les vis fournies.
- Für mehr Stabilität und Festigkeit kann man die Wände mit den mitgelieferten Schrauben am Boden befestigen.

- Voor een goede stabiliteit en stevigheid van de kooi, bevestigt u het beste de wanden aan de bodem met de meegeleverde schroeven.
- Para una mejor estabilidad y solidez de la jaula, fije las paredes al fondo con los tornillos suministrados.
- Para melhor estabilidade e solidez da gaiola, fixe as paredes ao fundo com os parafusos fornecidos.
- Для лучшей устойчивости и прочности каркаса закрепите стенки на дне с помощью прилагаемых винтов.

